Owner's Manual

Ceramic Cooktop

Model *CH 13 - (30 cm)*
 CH 14 - (60 cm)
 CH 15 - (90 cm)

 **KLEENMAID**
THE WORLD'S BEST

TABLE OF CONTENTS

<i>Introduction</i>		1
<i>Installation / Cut-out Dimensions</i>	<i>CH 13 (30cm)</i>	2
	<i>CH 14 (60 cm)</i>	3
	<i>CH 15 (90 cm)</i>	4
<i>Operating the Cooktop</i>		5
<i>Cooking Utensils</i>		5
<i>Care of the Ceramic Surface</i>		6
<i>Safety Warning</i>		7
<i>5 Year Warranty</i>		8
<i>Purchase Details</i>		9

INTRODUCTION

Congratulations on your purchase of a Kleenmaid appliance.

*You have chosen a quality product which has 5 year parts and labour warranty and to assist you with the use and care of your appliance you are entitled to a *free in-home demonstration.*

This booklet is a guide to help you achieve the best results from your cooking appliance, but we do advise that like all new products you will need to get to know your cooktop and you may need to modify your traditional cooking techniques to achieve the best cooking results.

We're sure you will enjoy using your Kleenmaid cooktop and we invite you to contact us on 1-800-072-144 (freecall) should you require any further information and if you would like to organise your free in-home demonstration.

IMPORTANT: *Connection to electrical mains must only be performed by a licensed electrical contractor.*

COLOR CO-ORDINATION

You have purchased a ceramic Cooktop of the latest flexible design which eliminates the need for a metal perimeter frame.

Your cooktop is fitted with stainless steel finished control knobs. Additionally you have been supplied alternative sets of white or black knobs. To change, simply lever the fitted knob upward with your fingers, and fit the color of your choice.

**In-home demonstration may not be available to purchasers who live outside our usual service areas. Please phone us on 1-800-072-144 to arrange your demonstration.*

**Description of the ceramic hob
Model CH 13**

(30 cm)

- Glass size: 288 x 510
- Includes a 1800W rectangular Hi-Lite area (A)
- An energy regulator with double control (B)
- An on-off light (C)
- A Residual heat lamp (D)

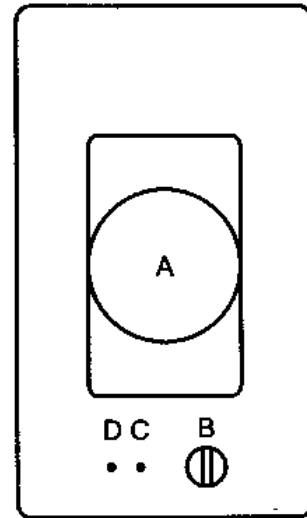

IMPORTANT

When tightening the holding clamps take care

NOT TO OVERTIGHTEN.

These clamps are strictly for location and are not intended to compensate for uneven bench top surfaces.

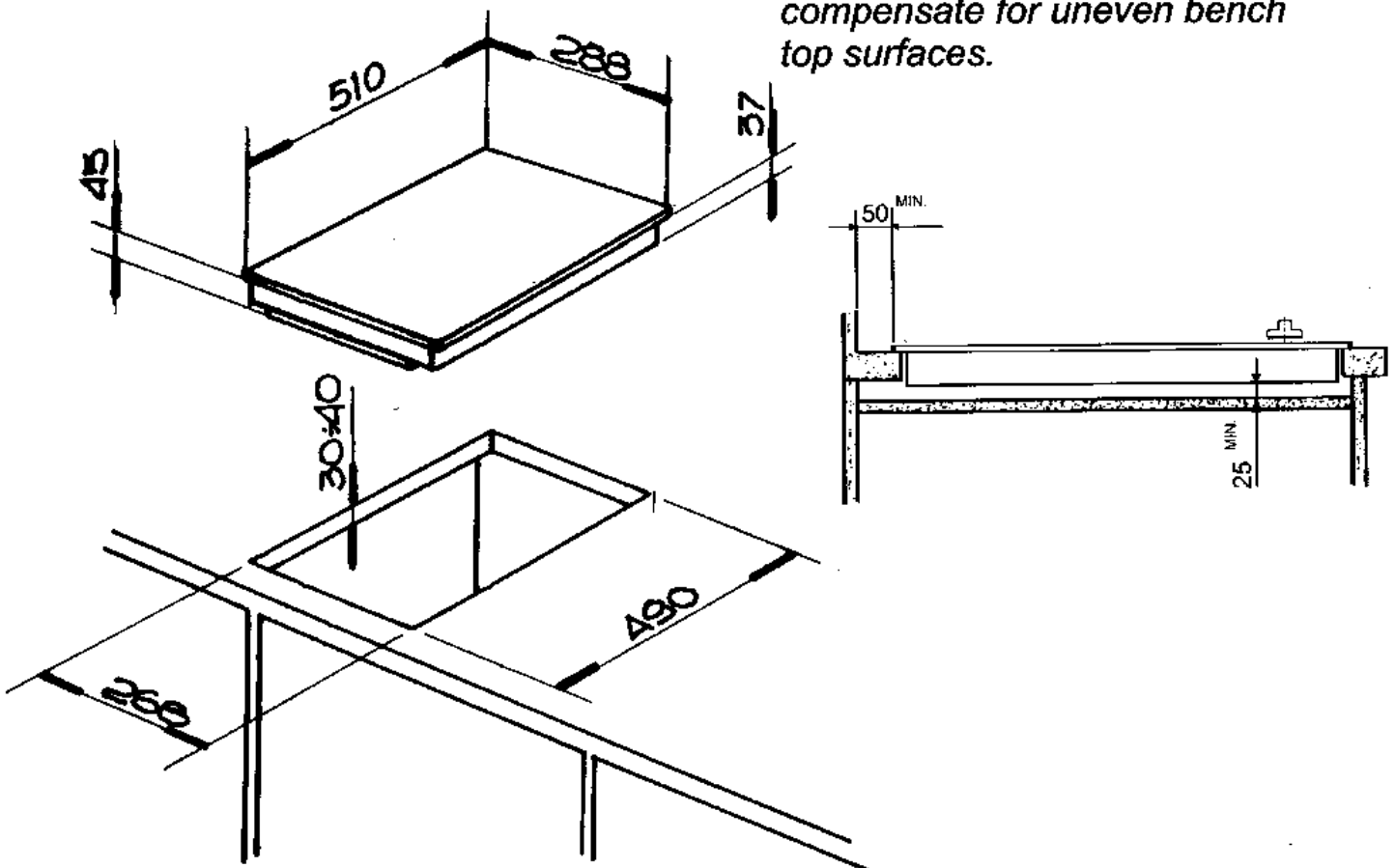

**Description of the ceramic hob
Model CH 14**

(60 cm)

- Glass size: 580 x 510
- Includes: * Two 1200W Hi-Lite 2 areas measuring \varnothing 165mm (A)
- * A 1700W Hi-Lite area measuring \varnothing 200mm (B)
- * A 2100W Hi-Lite area with a double ring (C)
- Three normal energy regulators (D)
- One energy regulator with double control (E)
- An on-off light (F)
- Residual heat lamps (G)

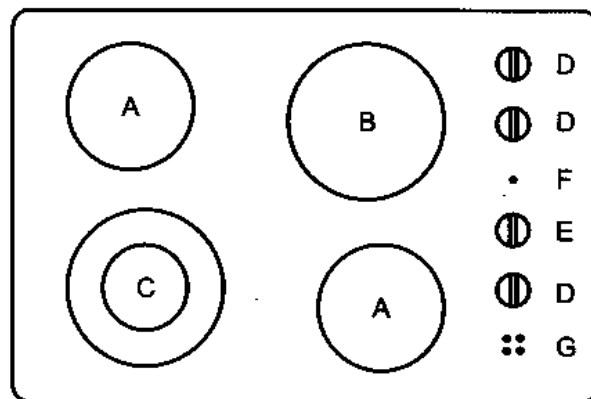

IMPORTANT

When tightening the holding clamps take care

NOT TO OVERTIGHTEN.

These clamps are strictly for location and are not intended to compensate for uneven bench top surfaces.

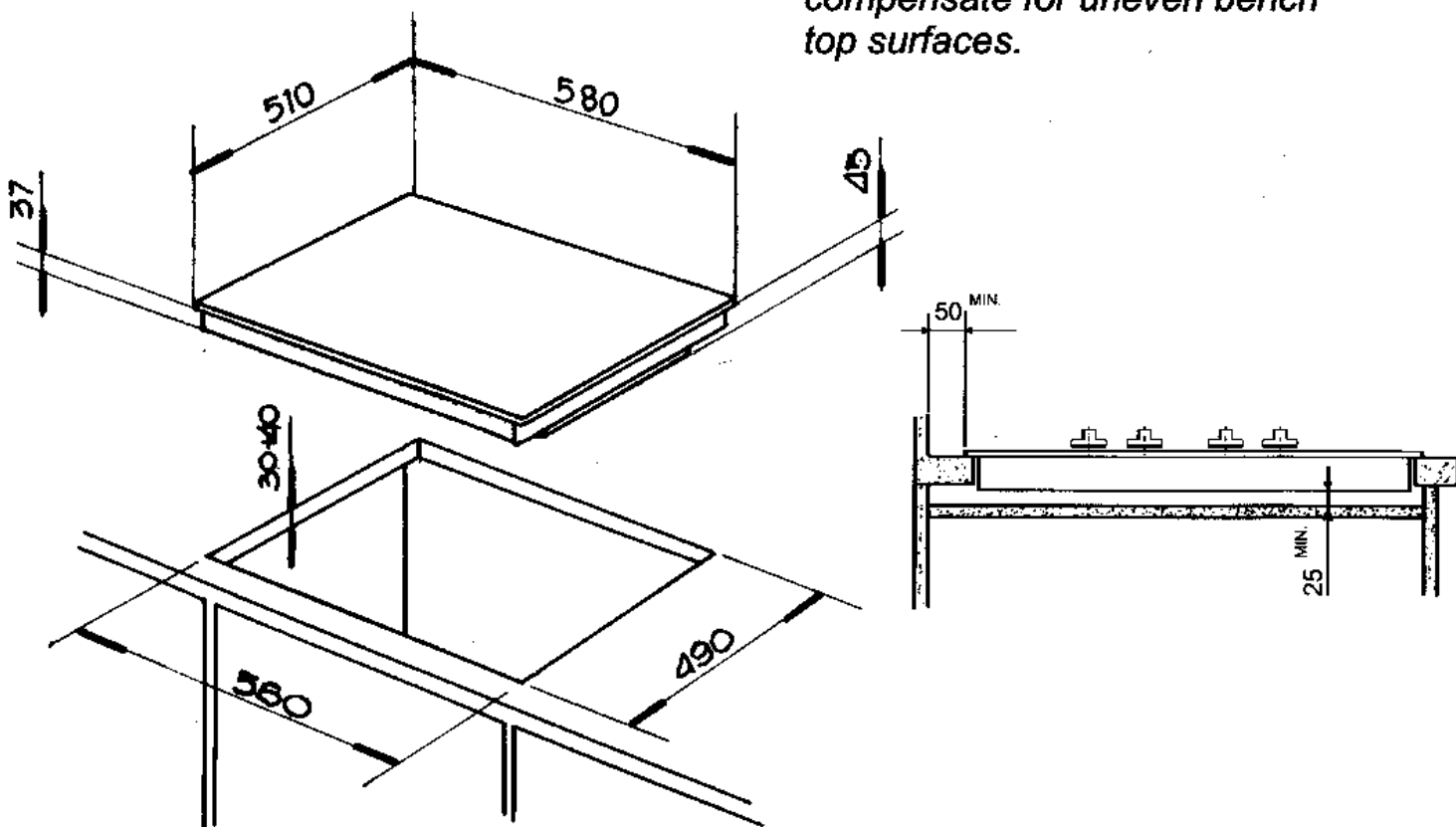

CH 15 model - Cm 90

Description of the ceramic hob Model CH 15

(90 cm)

- Glass size: 860 x 510
- Includes:
 - * Two 1200W Hi-Lite areas measuring \varnothing 165mm (A)
 - * Two 1700W Hi-Lite area measuring \varnothing 200mm (B)
 - * One 1800W Hi-Lite area with a rectangular extendable zone (C)
- Four normal energy regulators (E)
- One energy regulator with double control (F)
- An on-off light (G)
- Residual heat lamps (H)

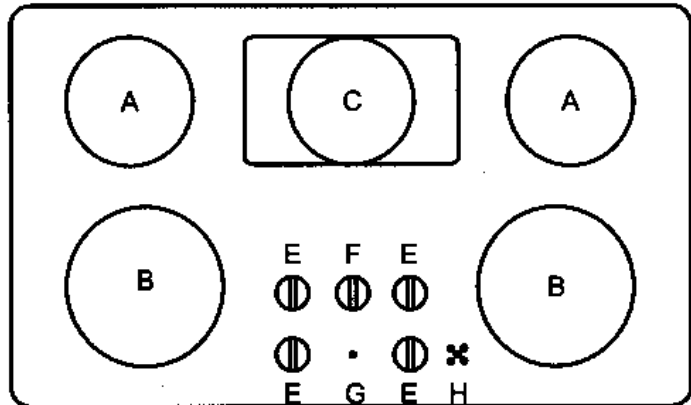

IMPORTANT

When tightening the holding clamps take care NOT TO OVERTIGHTEN. These clamps are strictly for location and are not intended to compensate for uneven bench top surfaces.

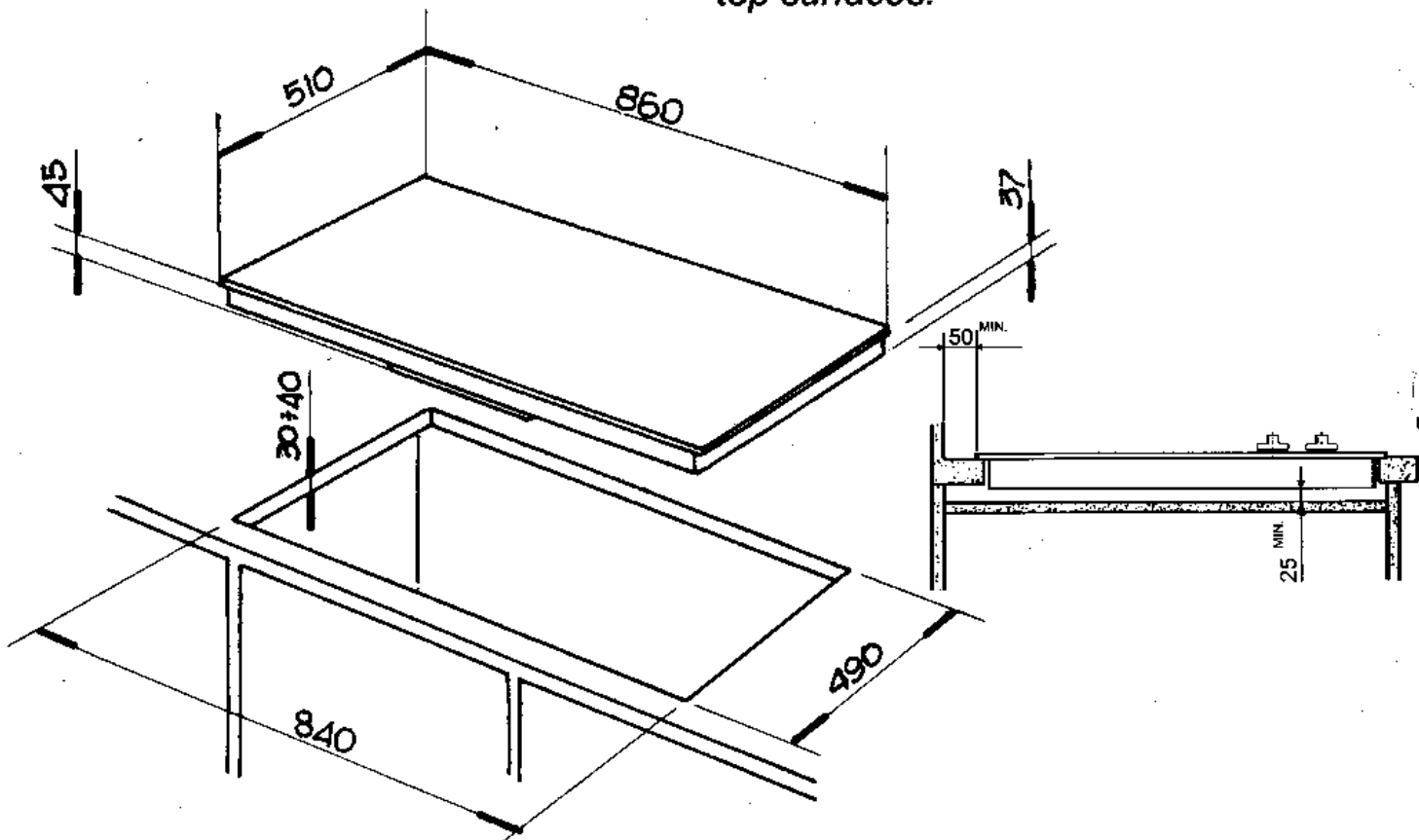

To operate the cooktop, rotate the knob to the desired heat setting.
The following chart indicates heat levels:

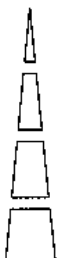
Element settings		Intensity	Type of cooking
single	dual	weak	melting butter
		gentle	melting chocolate
		low	cooking below boiling temperature
		medium	cooking boiling temperature
		high	frying
		full heat	boiling large quantities of liquid

WARNING:

DO NOT TOUCH THE COOKTOP SURFACE UNTIL YOU ARE CERTAIN THAT THE TEMPERATURE HAS REDUCED TO A SAFE LEVEL.

COOKING UTENSILS

To achieve best results when using your new cooktop, it is important that your saucepans are flat-based. You can check this by holding a ruler across the bottom of the pan.

If a gap of more than 1 mm. appears between the ruler and the base of the saucepan the pan is unsuitable for use. If it is either concave, or convex the pan will not make adequate surface contact with the cooktop, resulting in slow, ineffective cooking.

When selecting a saucepan, use one which is the same size or slightly larger than the element.

Suitability of saucepans

For best advice regarding the selection of appropriate cookware, we recommend that you contact your saucepan manufacturer or retail specialist.

Below is a general guide for your convenience:

1. Stainless Steel - Very suitable.

2. Enamelled Steel - Very suitable. However it is important to note that minimum pot base metal thickness of between 2.5 - 3 mm. is necessary to achieve best results.

3. Aluminium - Can be used but with caution. We advise you to contact your saucepan manufacturer to check suitability. Aluminium is a relatively soft metal and when making contact with the Ceramic surface may leave a metal residue on the glass surface. If this residue is not removed immediately with a suitable cleaner, it may react with the glass and if used repeatedly may burn onto and stain the surface.

Cookware guide continued...

4. Cast Iron - Can be used but with caution. With any heavy cookware the bases should be checked to ensure a smooth surface to avoid scratching. Due to the large volume weight of cast iron pots, the efficiency of such cookware is lower than that of stainless steel or enamelled steel cookware.

5. Glass - Can be used with caution. Check that the base surface is completely smooth to avoid scratching. Glass ceramic cookware is comparable in its performance with cast iron due to its low heat conductivity in the cookware base.

CARE OF THE CERAMIC SURFACE REMEMBER:

Do NOT slide your saucepan across the surface of your cooktop. Permanent scratching may result.

LIFT THE SAUCEPAN DIRECTLY ON AND OFF.

Damage to the perimeter edge may also occur if this warning is disregarded.

To ensure a long life and ongoing attractiveness of your cooktop we recommend that you use a cleaning cream and the quick scraper for cleaning your cooktop.

For best results, thoroughly clean the ceramic surface with cleaning cream before initial use of the cooktop. This pre-treatment conditions the surface, and if you clean your cooktop regularly, it will continue to look like new. Simply apply the cooktop cleaner to the glass surface with either a paper towel or a clean, damp cloth. Then polish off.

Regular use of cream not only cleans, but also protects the surface against future spillage stains.

Should you experience cooked-on crusty foods, use the scraper to lift the stain from the surface. Hold the scraper at a 30° angle and gently remove. Then polish off with cleaning cream.

Spillovers:

Wipe up splashes and spills immediately, using a clean damp cloth or damp paper towel.

Take care not to burn yourself.

SAFETY WARNING

Warning:

Ensure that the following substances are cleaned immediately from the surface

- DO NOT ALLOW TO COOL.

Sugar, Sugar Syrups and jam

Melted plastics and plastic wrap

Melted aluminium foil

These products may cause surface pitting if they are left to cool on the cooktop before cleaning.

Exercise caution when cleaning a hot cooktop to avoid burns.

Use the quick scraper to lift the stain from the hot surface before it becomes burnt on.

When cool, use the cleaning cream to restore the surface. A little boiling water will help soften the spill if required.

Metallic stains

may be removed with Goddards Glow. Apply gently with a soft cloth. Vigorous rubbing may cause fine scratches.

5 YEAR WARRANTY

5 YEAR WARRANTY

In addition to all statutory rights which you, the Consumer, have under all the relevant laws in respect of this appliance, during the first 5 years ownership as the original purchaser of the Kleenmaid Scala cooktop, we guarantee that any fault caused by faulty material or workmanship becoming apparent, will be rectified free of charge for parts or labour, provided that all service is performed during normal working hours by Kleenmaid or their designated Agent. Where the appliance is installed outside the normal servicing areas of the above, the Purchaser must pay the cost of transporting the appliance to and from the Agent or the Agent's travelling cost to and from the Purchaser's home

**"WARRANTY DOES NOT COVER
GLASS BREAKAGE DUE TO
IMPACT"**

Should you accidentally drop a heavy item on your cooktop causing it to break, immediately switch off the electricity. DO NOT USE YOUR COOKTOP. Call Kleenmaid Customer Services on 1-800-072-144 immediately to arrange a service call.