

COOKTOP

c o l l e c t i o n

Instructions for Use and Warranty Details

Solid Hotplate Cooktops

CH40S - 600 mm Stainless Steel

CH41W - 600 mm White

CH42B - 600 mm Black





Congratulations on the purchase of your new Kleenmaid appliance. This appliance has been designed and manufactured to give you years of reliable performance. For best results, carefully read the instructions on how to install your new appliance. Correct installation will avoid delays and unnecessary service calls.

Once installation is complete, read this booklet and get to know the controls and the features of your new appliance.

If you need further information call our

Customer Care Centre

1300 652 100

We reserve the right to alter the specifications with no influence on the operation of the appliance. This instruction manual cannot be reason for claim.

CONTENTS

- General description 2
- Use of controls 2
- Use of pans 3
- Cleaning 4
- Installation 5
- Connections sheamtic 7
- Wiring diagram 8
- Warranty and service 9

WARNING

- a) Repair of any fault in your hob must be carried out only by an Authorized Repair Service, otherwise the guarantee is not valid.

- b) The technical details and identification of the appliance are shown on the specification plate.

- c) Consult his plate before procceding with electrical connection.

- d) Electrical connection must be carried out by a specialist familiar with the laws and official regulations governing such while they are not covered by a pan.

Fill in the data table in the manual with all the data of the cooker that appear on its label.

MAKE

TYPE

**MAX
POWER -**

 (W)

TENSION

GENERAL DESCRIPTION

4 ELECTRIC HOTPLATE TYPE: EI-4E

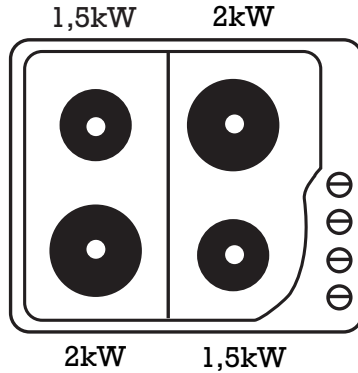

USE OF CONTROLS

- 1** Make sure that you operate the right control for the burner you wish to use

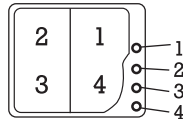

ELECTRICAL PLATES

Electrical plates have 6 positions giving different heat outputs. Table 1, gives a guide to these outputs.

To operate it, you may turn the control to the left or to the right, as you wish.

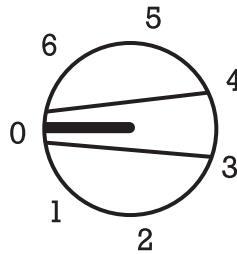

TABLE 1

0	MINIMUM		3	4	5	MÁXIMUM	
OFF	1	2					6
OFF	LOW		MEDIUM		HIGH		
	Keep warm		Boil and roast white meats, fish or puddings.		Boil and roast red meats, minced meat, omelettes.		
	Prepare delicate sauces and cremes		Boil potatoes, pulses, soups		Fry potatoes, fish, pasta.		
			Prepare sauces		Boil relatively large quantities of water		
1500W,p Hot	135 W	165 W	250 W	500 W	750 W	1500 W	
2000W,p Hot	175 W	220 W	300 W	850 W	1150 W	2000 W	

USE OF PANS

ELECTRICAL PLATES

Make sure that the diametre of the pan is equal to or bigger than the plate you are going to use.



The plate should not be lit without a pan.
The base of the pan should be flat and dry.

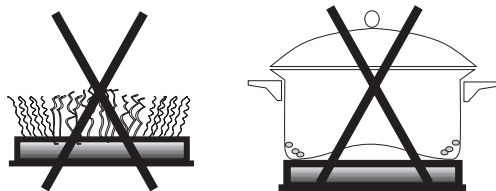

CLEANING

IMPORTANT: First of all, switch off the equipment.

If your top is stainless steel, there are adequate products available in shops that you may use. Once it is clean, rinse the top with water and a soft cloth.



If the top is enamelled, use soapy water to clean it. Never use abrasive products or pads. Immediately remove all stains of vinegar, lemon and acids spillage in general.

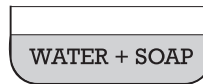

Clean electric plates immediately with water and soap. Then, heat the plate slightly and rub it with newspaper.

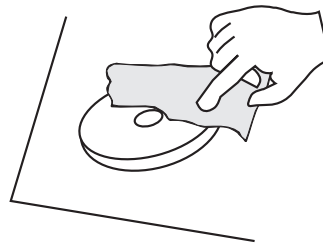

INSTALLATION

Before the installation, please check all measures of the equipment and fit-in housing.

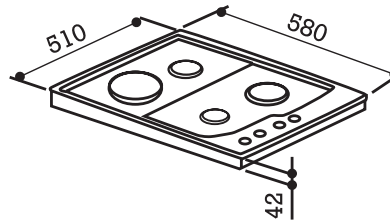

Cut out a piece of the worktop following the instructions. Equipment type "X" for fire protection grade.

NOTE:

The worktop must be provided with a shelf "A" so that the top cannot be reached from inside, due to the temperatures it reaches.

Such shelf will be located once the top has been fixed in the worktop.

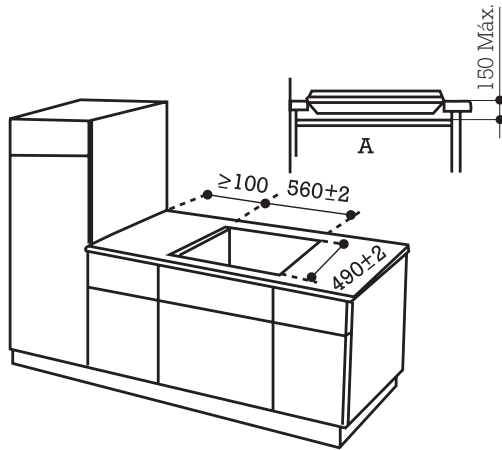

Place the hob face down on a table, and after removing the backing paper, affix the sealing gasket all around the hob.

A: operating table

B: joint

C: Bottom cover

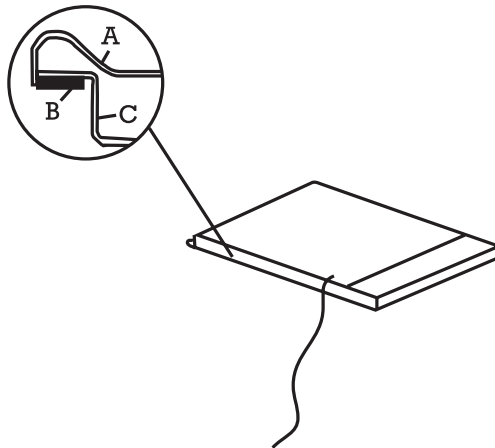

NOTE: DO NOT SILICONE SEAL THIS APPLIANCE TO THE WORK SURFACE.

INSTALLATION

Then, place the hob in the cavity in the woktop. Press down tightly so that sealing joint is perfectly closed.

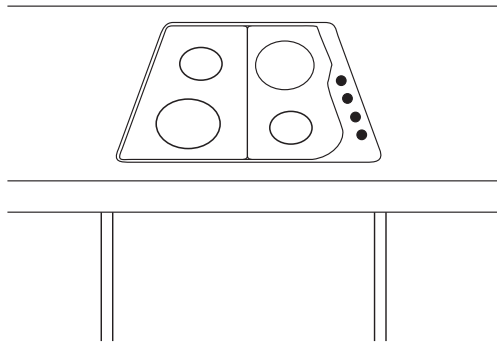

Fix the 4 clamps underneath the hob to the corresponding 4 corners of the cavity. (Clamps and nuts are supplied in the accessory bag).

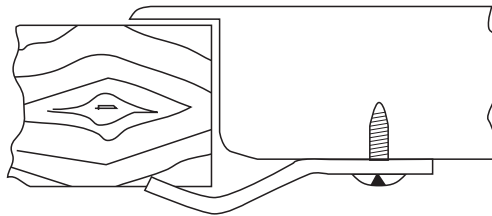

CONNECTIONS SCHEAMTIC

The hot plate is supplied with a power cable (N2GMH2G types) prepared for 220...240V AC.

If the type of connections to which the hotplate is to be installed is other than 220 to 240 V Ac remove the cable and make the connection according to the adjacent drawings. (The cable must support temperatures of up to 120°C).

The hotplate must be connected to the mains with a plug that meets the EEC 7 publication or with a multi-pole with a distance between the open contacts of a least 3 mm.

Total power

Hotplate: 60 cms., 6,3kW

PLATE	Three phase Δ					
	Voltage	Int.nominal by phases	Protection	Tensión	Int.nominal por fases	Protección
60 cms	220...240V~	27,5 A	32 A	220...240V~	14 A	16 A

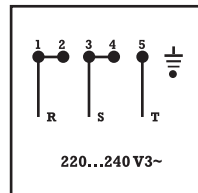
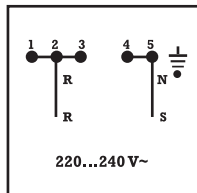
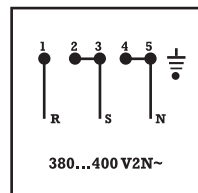
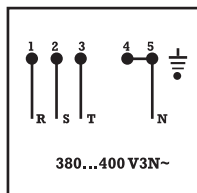

PLATE	Three phase Δ					
	Voltage	Int.nominal by phases	Protection	Voltage	Int.nominal by phases	Protection
60 cms	380...400V~	11 A	12 A	380...400V~	16 A	20 A



This device conforms to European directives 73/23/Cee and 89/336/CEE

WIRING DIAGRAM

- 1 - Hot Plate 1500W
- 2 - Hot Plate 2000W
- 3 - Hot Plate 1500W
- 4 - Hot Plate 2000W
- 5 - Switch
- 6 - Switch
- 7 - Switch
- 8 - Switch
- 9 - Neon
- 10 - Main Block

COLOURS

- T-R = Red
- AZ = Blue
- V-A = Green-Yellow
- M = Brown
- B = White
- N = Black

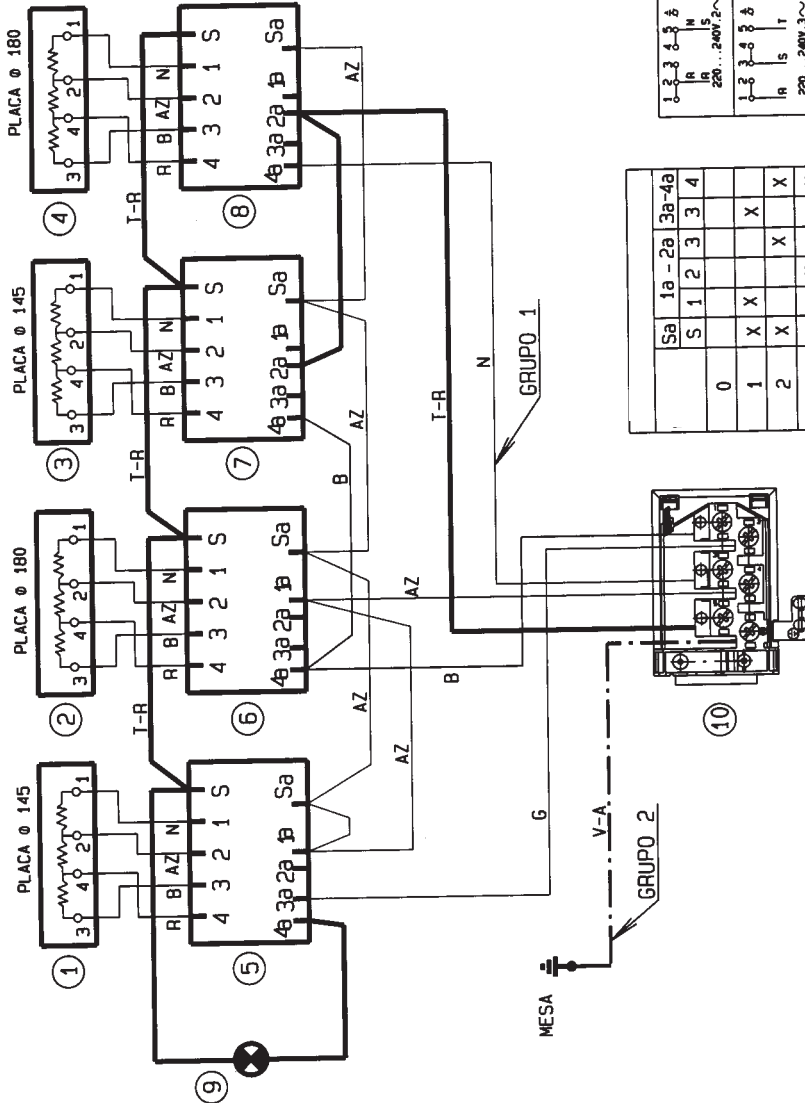

	1a	2a	3a	4a
Sa	S	1	2	3
0				
1	X	X		
2	X	X	X	
3	X	X	X	X
4	X	X	X	X
5	X	X	X	X
6	X	X	X	X

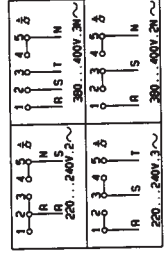

WARRANTY AND SERVICE

DOMESTIC WARRANTY - FULL FIVE YEAR WARRANTY

In addition to all statutory rights which you, the Consumer, have under the relevant laws in respect of this appliance, during the first five years of ownership as the original purchaser of this Kleenmaid appliance, we guarantee that any fault caused by faulty material or workmanship becoming apparent will be rectified free of charge for parts and labour, provided that all service is performed during normal working hours by Kleenmaid or their designated Agents. Where the appliance is installed outside the normal servicing area of the above, the Purchaser must pay for the cost of transporting the appliance to and from the Agent or the Agent's travelling cost to and from the Purchaser's home.

COMMERCIAL WARRANTY - ONE YEAR WARRANTY

When this appliance is installed in a commercial application, you, the Consumer, have under the relevant laws in respect of this appliance, during your first one year of ownership as the original purchaser of the Kleenmaid appliance, we guarantee that any fault caused by faulty material or workmanship becoming apparent, will be rectified free of charge for parts and labour, provided that all service is performed during normal working hours by Kleenmaid or their designated Agents. Where the appliance is installed outside the normal servicing area of the above, the Purchaser must pay for the cost of transporting the appliance to and from the Agent or the Agent's travelling cost to and from the Purchaser's home.

WHAT THESE WARRANTIES DO NOT COVER

We are not responsible for any damage or malfunction unless caused by a defect in material or workmanship. This includes but is not limited to abuse, misuse, improper installation and transportation damage. We are not responsible for any consequential damages from any malfunction.

WARRANTY DOES NOT COVER REPLACEMENT OF LIGHT GLOBES OR GLASS BREAKAGE DUE TO IMPACT

In case of fractured glass do not use your appliance.

WARRANTY REGISTRATION

Please complete the enclosed warranty card and post it to us or phone our Customer Call Centre.

SERVICE ASSISTANCE

To assist you when phoning our Customer Call Centre number to arrange a service call please complete the following details and have them ready when you call.

Model Number: _____ Date of purchase: _____

Kleenmaid Store purchased from: _____ Date of installation: _____

KLEENMAID CUSTOMER CALL CENTRE

CONTACT NUMBER

1300 652 100

Other products in Kleenmaid's
range of world's best appliances:

- Washers
- Dryers
- Vacuum Cleaners
- Dishwashers
- Cooktops
- Cookware
- Rangehoods
- Ovens
- Refrigerators & Freezers
- Sinks & Taps
- Waste Disposals

**For sales information on the full range of quality
kitchen and laundry appliances, phone 13 13 08**

Kleenmaid Head Office:

PO Box 5560, Maroochydore Business Centre, Queensland 4558



Printed on recycled paper.