Owner's Manual

Gas Cooktop

Models

CH-4 (White)

CH-5 (Stainless Steel)

CH-6 (Black)

INDEX

WELCOME to Kleenmaid and the superior cooking efficiency of Scala Cooktops.

<i>Appliance & Cut-out Dimensions</i>	3
<i>Installation Procedure & Positioning</i>	4
<i>Bottled or Natural Gas?</i>	5
<i>Flame Adjustment</i>	6
<i>Cleaning , & Operating the Burners</i>	7
<i>Operating Instructions</i>	8
<i>Cooking with Gas</i>	9
<i>Fault Guide</i>	10
<i>Electrical Wiring Diagram</i>	10
<i>Gas & Electrical Connection</i>	11
<i>Safety Warning</i>	11
<i>Service and Warranty</i>	Back Page

APPLIANCE DIMENSIONS

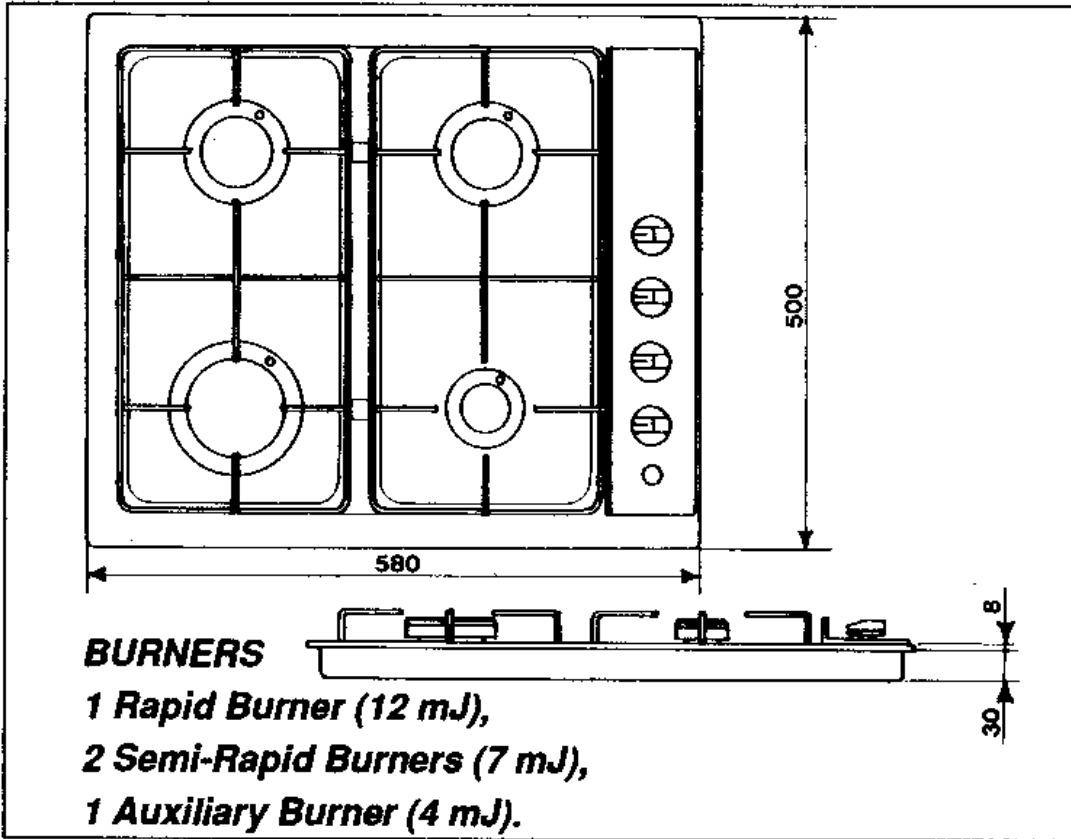

CUT-OUT DIMENSIONS

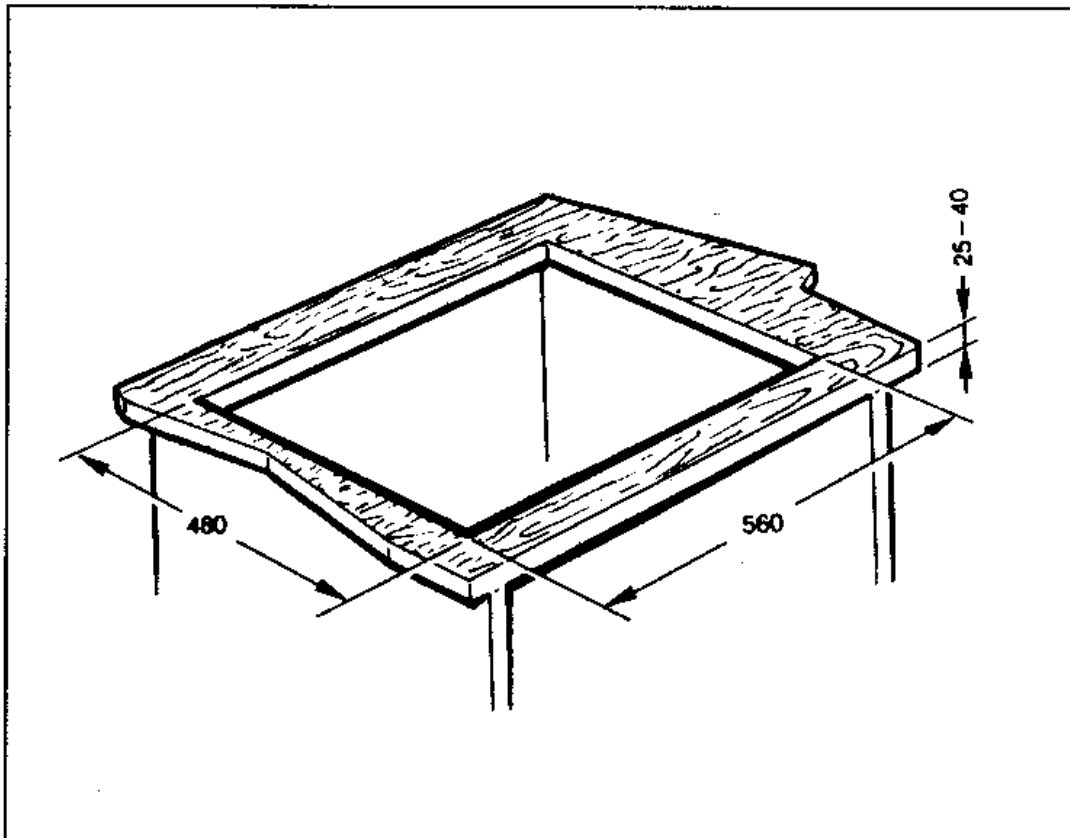

INSTALLATION PROCEDURE

**IMPORTANT:
THE APPLIANCE MUST BE INSTALLED BY A
QUALIFIED GAS FITTER , AND MUST BE
PROPERLY EARTHED.**

Your brand new hob complies with stringent AGA specifications and fits into any 600mm wide worktop which is at least 30mm thick. For your own personal safety it is essential that the installation is carried out by a suitably qualified gas fitter. Insist on a registered gas fitter who will undertake to work to a safe standard. The appliance must be installed in accordance with the Gas Safety (Installation and Use) Regulations.

POSITIONING

Failure to install the appliance correctly could invalidate the warranty and could lead to extreme danger.

Before deciding on where to position your hob you should bear in mind the following points:

- **The hob should be positioned in such a way that any combustible material (such as kitchen cupboards) should be at least 500mm above the top of the hotplate.**
- **The room should have good light, be well ventilated.**
- **The hob should be positioned at least 100mm away from the side cabinets.**
- **The rear wall should be covered with non-combustible material (tiles are ideal).**
- **Take care not to store combustible materials or flammable liquids below the hob.**
- **IMPORTANT. ALL SIDE AND REAR WALLS CLOSER THAN 250mm SHOULD BE COVERED IN NON-COMBUSTIBLE MATERIAL TO A HEIGHT OF 450mm.**

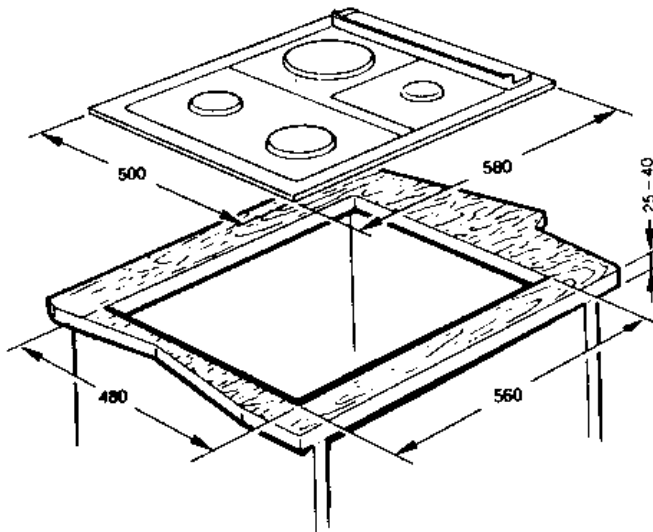

Cut out the hole according to the dimensions of the diagram.

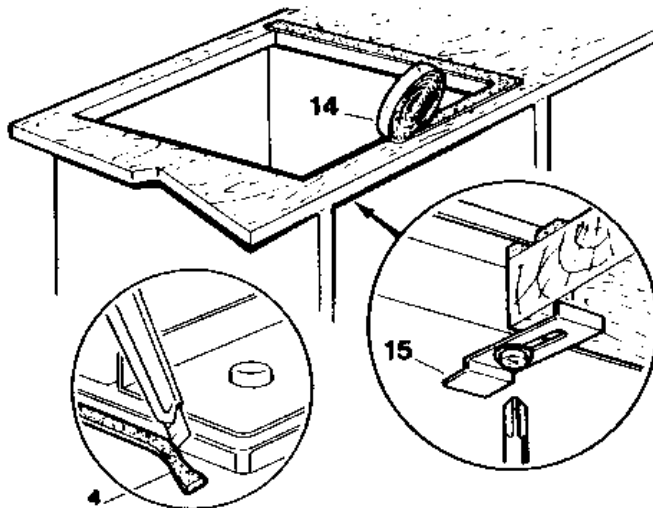

Spread the putty band (14). Adjust the cut-out, and fit the hob. Screw tight the four claw hooks (15), adapting them to suit the different thickness of the top. Remove the excess putty with a sharp knife (4).

BOTTLED OR NATURAL GAS ?

WARNING. Your appliance is designed to operate on either natural or bottled gas. The type of gas is clearly marked on the base of the appliance. It is highly dangerous to connect your hob to the wrong type of gas.

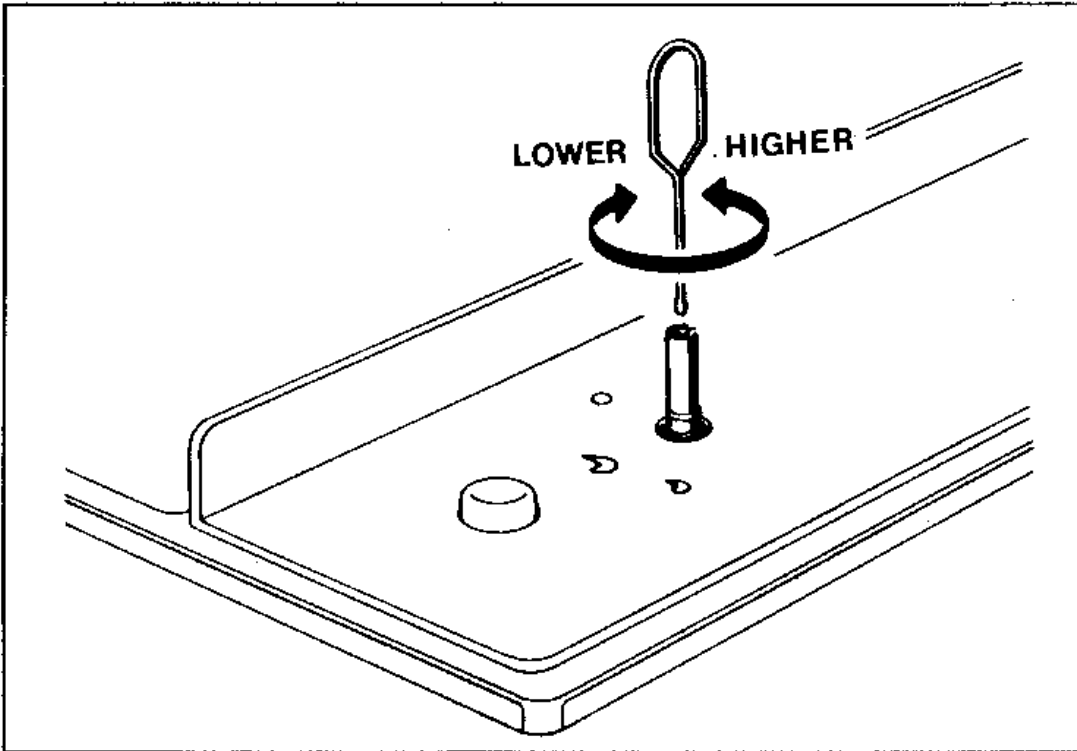

TURN DOWN OR MINIMUM SETTING

This has been set at the factory but can be also checked after the correct pressure has been adjusted. If adjustment is required; please observe the following:

- 1. Ignite the burner and set the knob to its minimum position.**
- 2. Remove the knob.**
- 3. Insert a suitable screwdriver into the valve shaft hole and rotate slowly until a minimum regular flame is achieved. (The flame will diminish when the screw is turned clockwise and increase when turned anti-clockwise).**
- 4. Replace the knob when the setting is right and check regulation by quickly rotating the tap from the maximum to the minimum delivery position. The flame must not go out.**

NOTE: IT IS IMPORTANT TO ENSURE THAT THE SETTING ON MINIMUM ALLOWS THE FLAME TO BURN WITHOUT EXTINGUISHING. (MAINTAIN A FLAME LENGTH OF APPROXIMATELY 4mm AT THE MINIMUM POSITION).

CLEANING

The appliance has been finished in tough, hard-wearing enamel or stainless steel. This provides an attractive, durable, and easy-to-clean surface.

The recessed spillage area has been designed to catch minor liquid or cooking overspills, and has been constructed without folds or corners for easy wiping.

The twin pan supports may be easily removed for cleaning either in the sink or in a dishwasher.

IMPORTANT: Never use abrasive powders or detergents. Always use soapy water and dry with a soft cloth.

CLEANING THE BURNERS

The three piece burners can easily be removed for cleaning. This is best carried out using a soft brush, detergent and water. Make sure the holes in the flame spreader are kept clean. After cleaning; wipe dry the hob. Rotate the flame spreader and burner body until they catch into position. Check parts have been replaced correctly by lighting the burner and allowing it to burn for a few seconds to dry completely.

NOTE: Should any solids or liquids inadvertently fall into the burner body remove the burner and clean with a damp cloth. Refit the burner and test the flame.

OPERATING THE BURNERS

- **TO LIGHT THE BURNER**, push in the appropriate knob and turn in an anti-clockwise direction to full on.
- **THEN**, immediately push in and hold ignition switch on the control until the burner lights.
- **THEN**, turn the tap to the required setting.
Note: The markings on the control panel are a guide for use when adjusting the burner.
- **TO SWITCH BURNER OFF**, turn the appropriate knob until the line on knob lines up with the **OFF** position on the control panel.

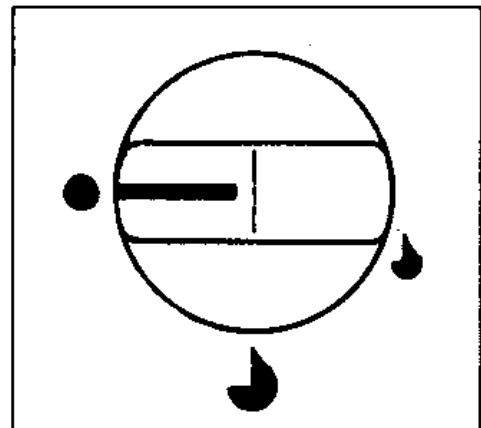

OPERATING INSTRUCTIONS

SELECTING THE CORRECT BURNER

If you are making the transition from electricity to gas, it is useful to remember that gas tends to cook more quickly. You may need a brief period to get accustomed to your new cooktop.

There are three different burner power inputs, each of which is variable. The first is the large high speed burner, which is ideal for rapidly boiling large pans. The medium burners are those most commonly used for steady boiling. Lastly, the economical small burner is ideal for simmering or for recipes where very fine control is needed.

CHOSING THE RIGHT UTENSILS

It may sound common sense, but some people have caused accidents by using the wrong kind of utensils.

- ***Always use pans with a thick bottom. Uneven pots and pans or those with a thin distorted base reduce the efficiency of the burners prolonging cooking time. For the same reason, you should not use pans that are too small.***
- ***Ensure that the base of any pans are dry before use.***
- ***DO NOT under any circumstances use aluminium foil or plastic containers on the hob.***

SAFETY FIRST - WARNING

This hotplate has been designed to be as safe as possible to use. Keep all saucepan handles turned to a safe position so that they are out of the reach of children and cannot be knocked accidentally as you walk past.

COOKING WITH GAS

When cooking in large pans, it is essential to maintain a minimum distance of 50mm between the side of the pot and worktop. After burning, the hot gases flow outwards under the base of the pan and may consequently burn the edge of the worktop.

Never place a pan on the fascia panel and make sure of a minimum distance of 15mm from the fascia panel.

Use the highest setting for boiling or searing (turn the control knob to the large flame setting), then turn the flame down to continue cooking.

The outer part of the gas flame is much hotter than the centre. Therefore, the tips of the flames should be in contact with the base of the pan and not spread out to the sides. Flames which spread out to the sides of the pan merely warm up the air.

In contrast to those used on electric hotplates, pan bases do not need to be even for gas cooking. Through the spreading action of the flame, heat reaches all parts of the pan.

Any type of pan is suitable for gas cooking, although thin pan bases will conduct heat to the food inside more quickly than thicker ones and because heat is not being evenly distributed there is a danger that food may be overheated in places. Therefore, when using a thin saucepan, stir the food more often. Thicker saucepans lessen the risk of food overheating in places, as better distribution of heat is possible.

It is advisable not to use saucepans which are too small. Also, wide, flat pans are more suitable than narrow, tall ones, since they heat up more quickly.

Using a small pot on the large burner simply results in wasteful gas consumption. The best procedure is to cook with small pots on the small burner and medium burner.

Cooking in a covered pot is much more efficient because less

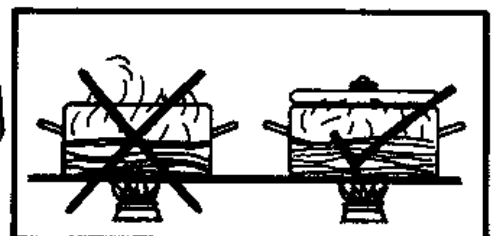
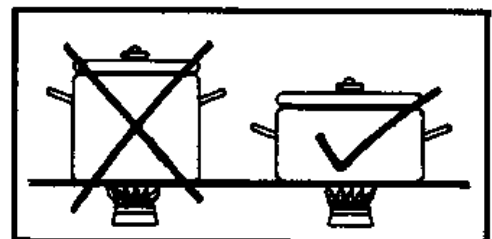
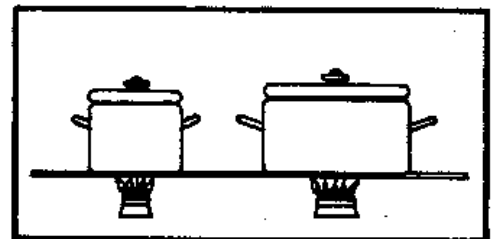
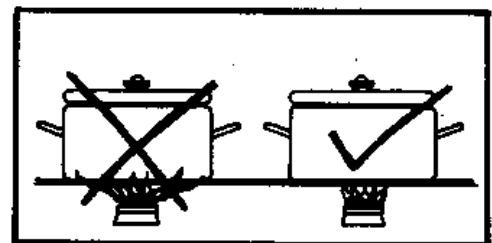

NOT WORKING PROPERLY? (PART 2)

* UNEVEN OR YELLOW FLAME RATHER THAN CLEAR BLUE:

Switch off immediately and check the following points:

- Are the burners fitted correctly ?
- Are the burners and the holes in the burner cap clear ?
- Check that no dust has fallen into the flame turning it yellow. Relight and if the flame is still yellow, call service agent. DO NOT USE hob again until service agent has checked it out.

* BURNER FALLING TO IGNITE ?

Check that power is turned on and that the fuse has not blown. Make sure that the igniter terminal isn't coated with food spillage, preventing it from sparking.

* SPARK BUT NO GAS ?

Make sure that gas is turned on. Check that the burner holes are not blocked.

* SMELL OF GAS ?

Check to see if any gas tap has been inadvertently left on. If they are all off, then immediately switch off gas at mains and call service agent. DO NOT under any circumstances press igniter or search for leak with naked flame.

* STILL NOT WORKING ? Call the service agent.

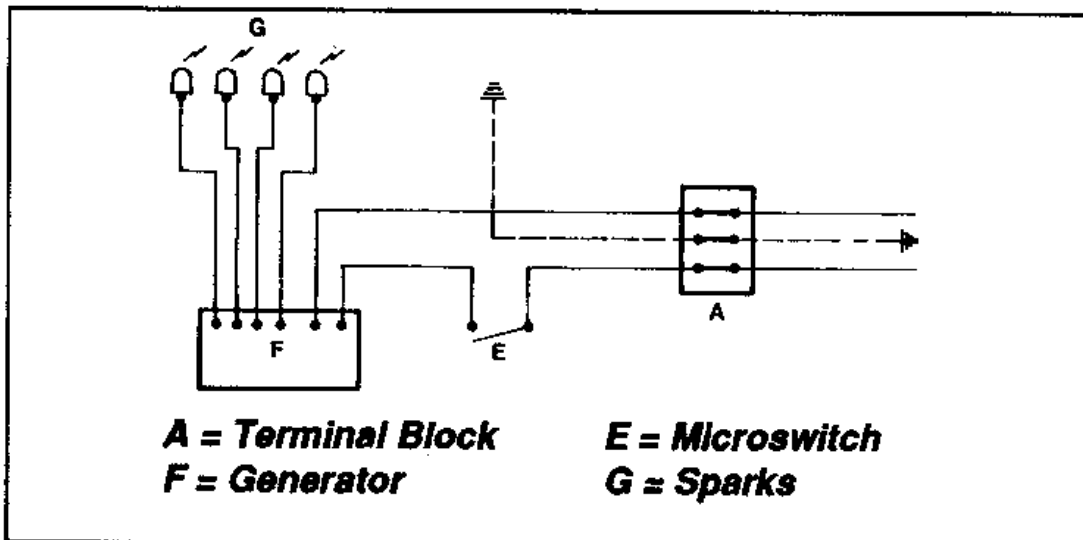

Any electrical wiring must be carried out in compliance with the local electricity board regulations by a qualified electrician.

WARNING: ALL APPLIANCES MUST BE EARTHED.

Our company cannot accept responsibility for any damage to persons or property arising from faulty connection or non connection to earth. The hob must be supplied via a suitable double pole isolating switch placed in a readily accessible position adjacent to the unit. Before connection or installing the hob electricity supply must be switched off.

The regulator supplied should be fitted to the 1/2 BSP elbow (male) at the rear of the appliance when it is connected to NG.

For LPG or Town Gas connection, please request a special kit.

DANGER:

NEVER SPRAY AEROSOLS IN THE VICINITY OF THIS APPLIANCE WHILE IT IS IN OPERATION. WHERE THIS APPLIANCE IS INSTALLED IN MARINE CRAFT OR IN CARAVANS, IT MUST NOT BE USED AS A SPACE HEATER.

5 YEAR WARRANTY

In addition to all statutory rights which you, the Consumer, have under all the relevant laws in respect of this appliance, during the first five years of ownership as the original purchaser of the Kleenmaid Scala Gas Cooktop, we guarantee that any fault caused by faulty material or workmanship becoming apparent, will be rectified free of charge for parts and labour, provided that all service is performed during normal working hours by Kleenmaid or their designated Agent. Where the appliance is installed outside the normal servicing area of the above, the Purchaser must pay the cost of transporting the appliance to and from the Agent or the Agent's travelling cost to and from the Purchaser's home

for service

call 1-800-072-144 (Freecall)

KLEENMAID
THE WORLD'S BEST