

# CH600X, CH600FFX CH600W, CH600FFW

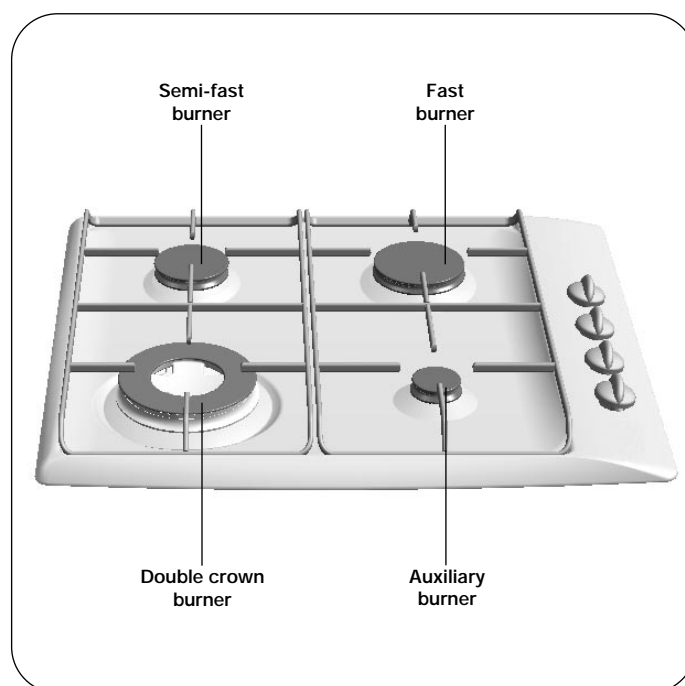

 **KLEENMAID**

MANUFACTURED BY **Brandt**

We would like to congratulate you for buying one of our hobs.  
 To get the best out of your new appliance we strongly advise you to **read carefully** all the information contained in this instruction manual :

## PART 1 FOR THE INSTALLER

<u>GENERAL INFORMATION</u>	P. 3
<u>BUILDING THE HOB IN</u>	P. 3
<u>HOW TO INSTALL THE HOB</u>	P. 4
<u>HOW TO FASTEN THE HOB</u>	P. 4
<u>HOW TO CONNECT THE COOKING HOB TO THE ELECTRICAL SUPPLY</u>	P. 4
<u>GAS CONNECTION</u>	P. 5
<u>HOW TO MAKE THE CHANGE OF GAS TYPE FOR THE COOKING HOB.</u>	P. 6-7
<u>GAS RATING</u>	P. 11
<u>COOKING GUIDE</u>	P. 12

## PART 2 FOR THE USER

<u>HOW TO USE THE GAS BURNERS</u>	P. 8
<u>WHICH SAUCEPANS TO USE ON THE GAS BURNERS</u>	P. 9
<u>HOW TO CLEAN YOUR HOB</u>	P. 10
<u>QUESTIONS/ANSWERS</u>	P. 10
<u>AFTER-SALES SERVICE</u>	P. 12

### Look out for...



tips



warnings



things to read



contacts



## **YOUR COOKING HOB IS DELIVERED REGULATED**

### **FOR MAINS GAS (NATURAL GAS).**

Hobs with one or several gas burners must be installed in conformity with current regulations and used solely in an area that is well aired. These hobs have been designed to be used by householders in domestic premises.

**Please read these instructions before installing and using your cooking hob.**

With a view to the constant improvement of our products, we reserve the right to make any changes in their technical, functional or aesthetic characteristics as a result of technical evolution.

These hobs are designed exclusively for the cooking of drinks and foodstuffs.

These products do not contain any asbestos-based component parts.

# Part 1: For the Installer

## ● GENERAL INFORMATION

**THIS APPLIANCE SHOULD BE INSTALLED BY A QUALIFIED TECHNICIAN / INSTALLER.**



• Prior to installation, ensure that the local distribution conditions (nature of the gas and gas pressure) and the adjustment conditions of the appliance are compatible.

• On this subject, combustion can take place only if oxygen from the air is present, so this air must be constantly renewed and the combustion products must be evacuated (a minimum air input of 2 m<sup>3</sup>/hour per kw of gas energy is required)..

- These hobs are designed to be used by private individuals in their homes. the adjustment conditions are stated on a label in the bag and also on the packaging.
- Since this appliance is not connected to a combustion products evacuation device, it must be installed in accordance with current installation regulations and used in a well-ventilated place. particular attention should be given to the relevant requirements regarding ventilation.

## ● BUILDING THE HOB IN

- The hob must be built into the worktop of a support cupboard. This worktop must be at least 3 cm thick and heat-resistant or else coated with a heat resistant material.
- A side-clearance of at least 30 cm should be left to the right and left of the hob. A tall cupboard or partition too close to the hob would hinder free movement of kitchen utensils.

• If a horizontal partition is put under the hob, it must be placed between 10 and 15 cm from the bottom of the work top. In any case, do not keep any sprays or pressurized containers in the compartment which could be just under the hob.

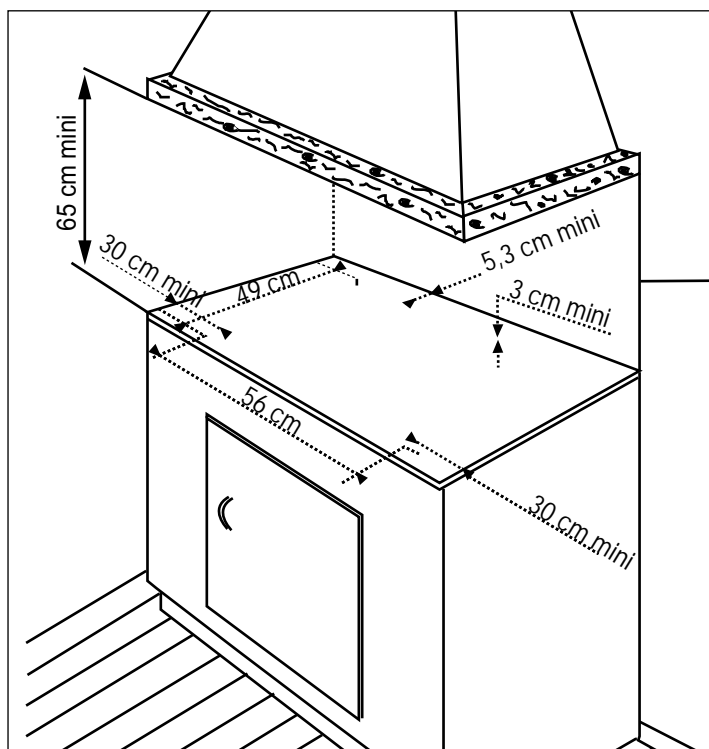

This height should be in accordance with Local Gas Authorities and the manufacturer of the rangehood

# Part 1: For the Installer

## HOW TO INSTALL THE HOB

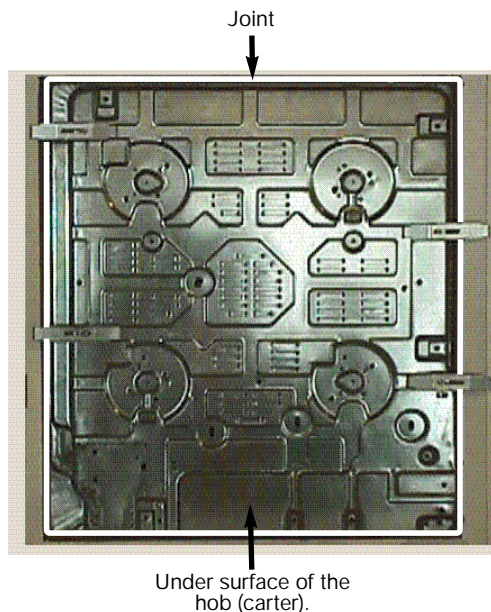

- Glue the joint supplied in the sachet before installing the hob.

Before inserting the hob:

1- Turn over the hob and pose it with precaution above the opening of the support in order not to damage the knobs, lighting stubs and the metal gas security rods.

2- Glue the foam joint delivered with the apparatus to the external rim of the carter. This joint ensures sealing between the cooking hob and the work surface

3- Place the cooking hob in the opening of the support unit taking care to centre it well in the cut-out..

4- Fit the burner heads, burner caps and the grids..

5- Connect the hob power supply cable to the electrical installation of the kitchen. See "How to connect the cooking hob to the electrical supply".

6- Connect the gas. See "How to connect the cooking hob to mains gas" or "How to connect to connect the cooking hob to Butane /Propane gas".

## HOW TO FASTEN THE HOB

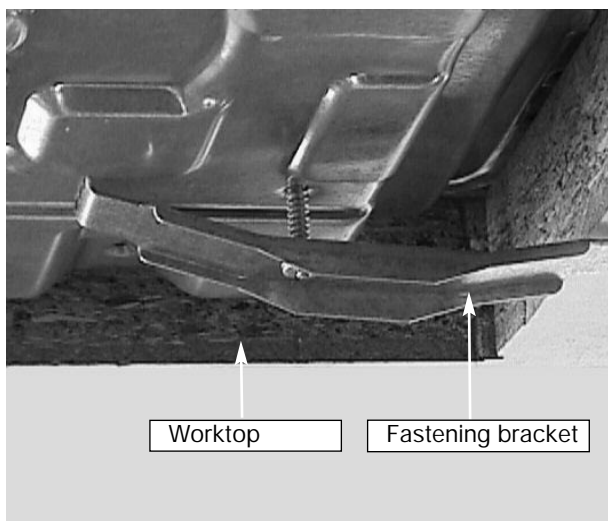
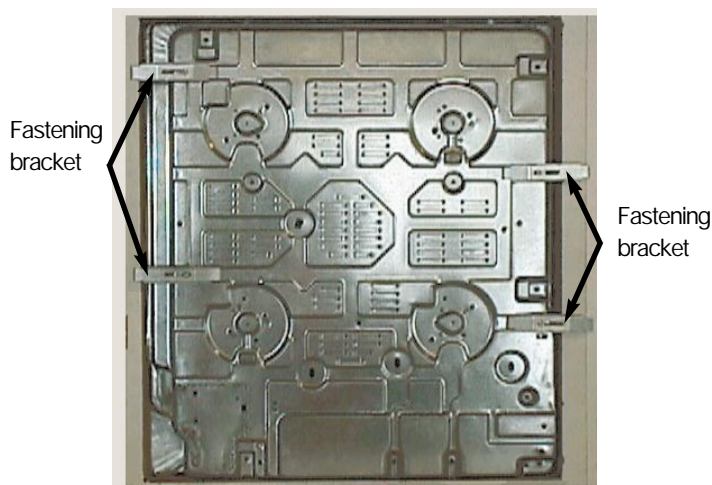

If you wish to clamp the hob, ensure that the four fixation plates supplied in the sachet are used.

## HOW TO CONNECT THE COOKING HOB TO THE ELECTRICAL SUPPLY.

- The cooking hob must be connected to 240v single phase mains supply by the intermediary of a two phase + earth homologated EEC 7 plug or a single pole cut-off device with a contact opening by at least 3mm.

If the mains connection cable is damaged it must be replaced by your After-Sales Service because special tools are needed.

**Warning:** The protection wire (green /yellow) is connected to the earth terminal ⊕ of the apparatus and must be connected to the earth terminal ⊕ of the installation.

CROSS SECTION OF THE CABLE TO USE	
Network	240 V ~ - 50 Hz
Cable H05V2V2F - T90	3 conductors of which 1 is to be earthed
Cross section of conductors in mm <sup>2</sup>	1
Fusible	10 A

---

# Partie 1: For the Installer

---

## ● GAS CONNECTION

---

### PRELIMINARY REMARKS



- If the hob is installed above an oven or if the proximity of other heating elements might cause the connection to heat up, it is essential that rigid connections are used.
- **Whatever type of connection is chosen, check its air-tightness after installation using soapy water.**
  - Duplicate data plates should be attached to adjacent surfaces
  - The operation of the appliance must be tested before leaving.
  - If the appliance cannot be adjusted to perform correctly contact the local gas authority.

### CONNECTION OPTIONS

- Mains gas (natural gas) or LPG.
- Back right hand corner 1/2 inch male BSP thread.
- **Rigid pipe connection.**  
Installation to be in accordance with AG 601. Make the connection at the end of the elbow fitted onto the appliance.
- The test point pressure should be set with the semi-rapid and the rapid burners operating at maximum.

# Part 1: For the Installer

## ● HOW TO MAKE THE CHANGE OF GAS TYPE FOR THE COOKING HOB

**Disconnect the apparatus before intervention**

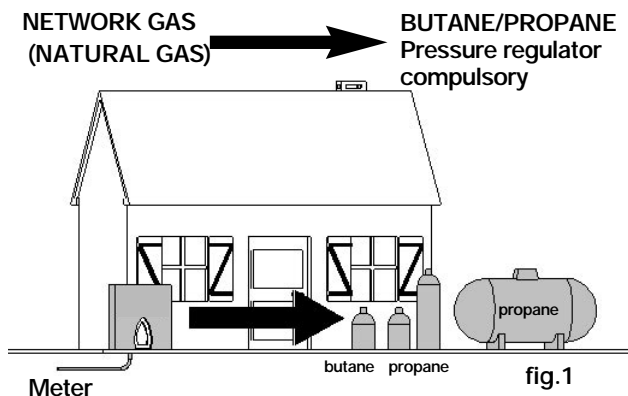

**CHANGING FROM NETWORK GAS (NATURAL GAS - AN AIR PROPANE / BUTANE MIXTURE TO THE BUTANE/PROPANE GAS (FIG. 1)**

**PRELIMINARY REMARKS**

- Your cooking hob is delivered regulated for network gas (natural gas). The injectors necessary for adaptation to LPG can be found in the bag containing the manual.

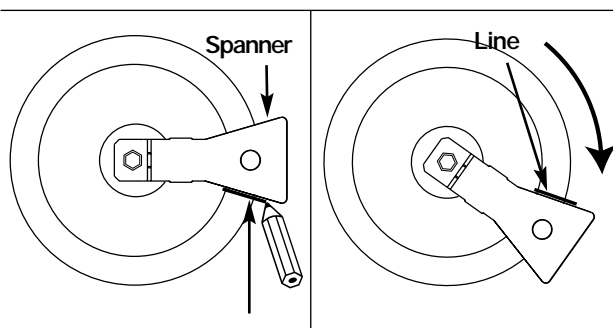
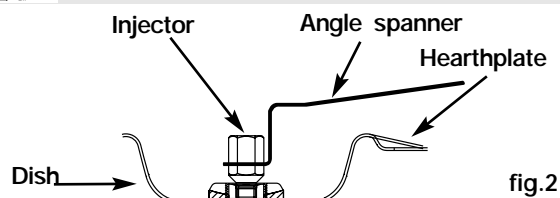

When carrying out this operation, you should **successively**:

- ADAPT THE GAS CONNECTION
- CHANGE THE INJECTORS
- ADJUST THE RETARDER ON THE TAPS

**1** ADAPT THE HOB CONNECTION to the new gas adjustment. Refer to the paragraph "Gas connection".

**2** CHANGE THE INJECTORS in the following way:

- Remove the supports, and all the burner caps and heads.
- Using the spanner supplied, unscrew the injectors at the bottom of each dish and remove them (fig. 2).
- Replace these with the injectors supplied in the bag, in accordance with the gas characteristics table; To do this:
  - First, screw them by hand.
  - Put the spanner well onto the injector.
  - Screw them right in without forcing.
  - With a pencil draw a line on the hearth plate as indicated (fig. 3).
  - Turn the spanner clockwise until the line appears on the other side (fig. 4).
- Remount the heads, caps and grids of all the burners.

**3** ADJUST THE RETARDER ON THE TAPS located under the knobs. Proceed as follows:

- Pull up the knobs and remove them.
- Using a small screwdriver, **screw fully** the brass, adjustment screw (yellow) (fig.5) **clockwise**.
- Work on **one tap at a time**.
- Put the knobs back in place making sure they are turned in the right direction.

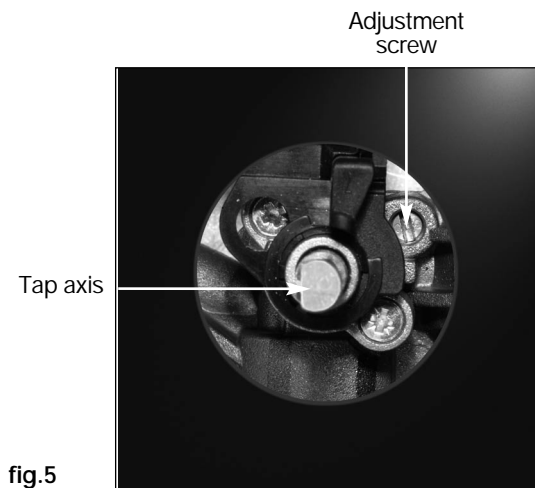

# Part 1: For the Installer

## ● HOW TO MAKE THE CHANGE OF GAS TYPE FOR THE COOKING HOB

**Disconnect the apparatus before intervention**

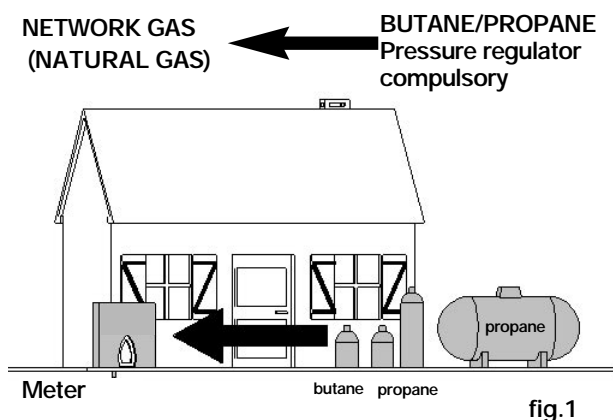

### CHANGING FROM BUTANE / PROPANE GAS TO NETWORK GAS (NATURAL GAS) (FIG. 1)

When carrying out this operation, you should successively:

- ➊ ADAPT THE GAS CONNECTION
- ➋ CHANGE THE INJECTORS
- ➌ ADJUST THE RETARDER ON THE TAPS

➊ ADAPT THE HOB CONNECTION to the new gas adjustment. Refer to the paragraph "Gas connection"

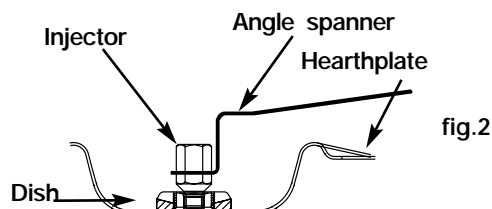

➋ CHANGE THE INJECTORS in the following way:

- Remove the supports, and all the burner caps and heads.
- Using the spanner supplied, unscrew the injectors at the bottom of each dish and remove them (fig. 2).
- Replace these with the injectors supplied in the bag, in accordance with the gas characteristics table at the end of this instruction manual. To do this:
  - ⇨ First, screw them by hand.
  - ⇨ First, screw on the injector tightly by hand.
  - ⇨ Screw them right in without forcing.
  - ⇨ With a pencil draw a line on the hearth plate as indicated (fig. 3).
  - ⇨ Turn the spanner clockwise until the line appears on the other side (fig. 4).
- Remount the heads, caps and grids of all the burners.

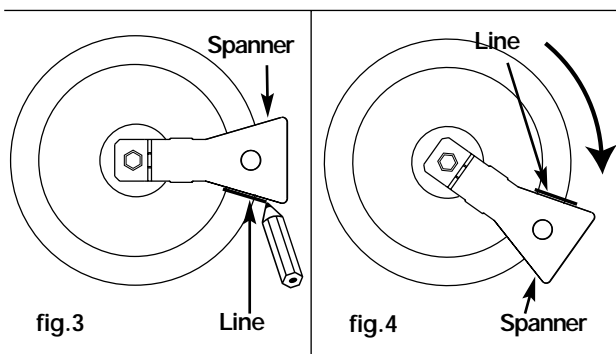

➌ ADJUST THE RETARDER ON THE TAPS located under the knobs. Proceed as follows:



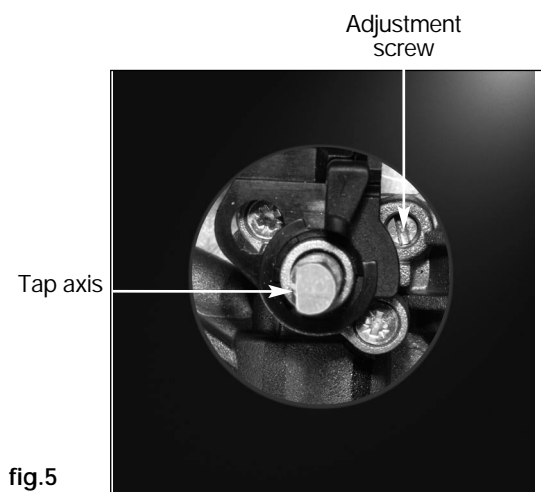

- Work on **one burner at a time**:
  - light the burner and turn the knob to maximum position
  - remove the knob of the corresponding tap,
  - using a screwdriver, unscrew the yellow, brass, adjustment screw (fig.5) turning it round twice, **anti-clockwise**.
  - put back the knob, and turn it to minimum position,
  - remove the knob again then turn the adjustment screw **clockwise** as low as possible without extinguishing the flames,
  - put back the knob then turn it several times from maximum position to minimum position : **the flame must not be extinguished**. Otherwise, re-adjust it by slightly screwing or unscrewing the adjustment screw so that a stable flame is obtained when the knob is turned from maximum to minimum position.



# Part 2: For the User

## ● HOW TO USE THE GAS BURNERS





### **LIGHTING THE HOB WITHOUT GAS SECURITY DEVICE (DEPENDING ON MODEL)**

- Select the required burner by referring to the symbols located near the knobs (e.g. :  for the front right-hand burner).
- Each burner is supplied by a tap. To turn this on, press it down and turn it anti-clockwise  .  
The gas is turned off when the knob points to (●)
- To turn the gas down the knob should be turned from  to  .
- Your hob is equipped with a burner ignition device integrated into the knobs: To ignite a burner, press down and turn the knob anti-clockwise until it is pointing to the maximum position  .

 Do not spray aerosols in the vicinity of this appliance while it is in operation. Where this appliance is installed in marine craft or in caravans, it shall not be used as a space heater.

Keep the knob pressed down to activate a series of sparks until the burner lights.

### **LIGHTING THE HOB WITH GAS SECURITY DEVICE (DEPENDING ON MODEL)**

- Select the required burner by referring to the symbols located near the knobs (e.g. :  for the front right-hand burner).
- A tap equipped with a **gas safety device controls** each burner and if the flame is accidentally extinguished (spills, draughts etc...) this device automatically closes down the gas supply and prevents gas escaping.
  - Your hob is equipped with a burner ignition device integrated into the knobs.
  - To ignite a burner, press down and turn the knob anti-clockwise  until it is pointing to the maximum position  .
  - To turn the gas down the knob should be turned from  to  .

 When the flame appears keep the knob well pressed down for 3 to 5 seconds to activate the safety device.

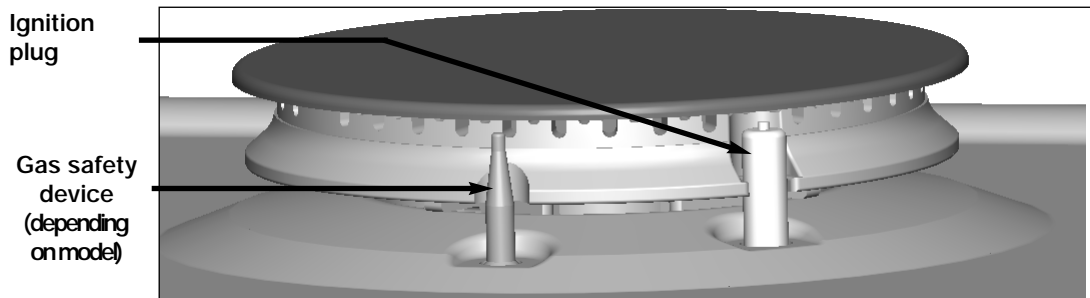

### **NOTE :**



- If the flame is accidentally extinguished just re-light it normally following the ignition instructions.
- Your hob is equipped with an integrated ignition device ; it is, therefore, normal that a series of sparks is produced on all the burners.
- If it becomes difficult to turn a knob **DO NOT FORCE IT**. Have the installer see to it immediately.
- In the case of a power cut, automatic lighting will not work. In these circumstances, matches may be used

## Part 2: For the User

### ● CHOOSING THE RIGHT SAUCEPAN FOR THE GAS BURNERS

- Use saucepans with the following diameters

Auxiliary burner	Semi-fast burner	Fast burner	Double crown burner
12 to 16 cm	14 to 22 cm	16 to 26 cm	20 to 30 cm



- Adjust the flames so that they do not lick up the side of the saucepan.
- Do not use a saucepan with a convex or concave base
- Do not leave an empty saucepan on the gas.
- Do not use saucepans that partially cover the knobs.

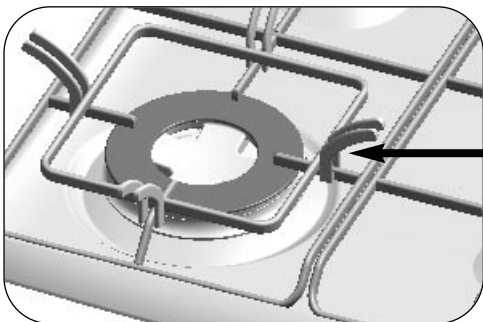
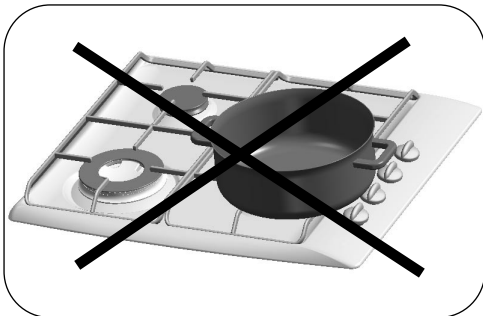

- Only cooking tables with "Double crown" burners are equipped with a specific "Wok" grid support. This grid allows using receptacles with a concave bottom. Associated with a "Double crown" burner, it gives a better distribution of flames over large receptacles such as Woks.

#### RECOMMANDATIONS :

- Using a gas-cooking appliance produces heat and humidity in the room in which it is installed. Your kitchen should be well ventilated. Keep all natural vents open or install a mechanical ventilation device (mechanical cooker hood).
- Intensive and prolonged use of the appliance may necessitate extra ventilation - opening a window for example or producing more efficient ventilation by increasing the power of the existing mechanical ventilation (a minimum air input of 2 m<sup>3</sup>/hour per kW of gas energy is required).
- As a safety measure, remember **to turn off** the network gas mains or the tap on the butane/propane cylinder after use.

# Part 2: For the User



## ● HOW TO CLEAN YOUR HOB.



It is easier to clean your hob before it has completely cooled. However, you should never clean your appliance while it is on. Turn all the switches to the zero position.

MAINTENANCE OF THE PAN SUPPORTS AND GAS BURNERS	HOW TO PROCEED	PRODUCTS AND ACCESSORIES TO USE
	<ul style="list-style-type: none"> <li>• For difficult stains use a non-abrasive paste, then rinse with clean water. Wipe the burner caps carefully before using your hob again. If the gas holes on the burner get clogged or the ignition plugs get dirty clean them with a small hard-bristled brush (non-metallic).</li> <li>• The gas injector is the pot-shaped part in the middle of the burner. Be careful not to obstruct it when cleaning, as this would interfere with the performance of your hob.</li> </ul>	<ul style="list-style-type: none"> <li>• A mild paste cleaner.</li> <li>• Kitchen sponge.</li> <li>• Small hard-bristled brush</li> </ul>

## Questions / answers

QUESTIONS	ANSWERS
<ul style="list-style-type: none"> <li>• <b>Lighting the burners:</b> <ul style="list-style-type: none"> <li>- When the knob or button is pressed, there are no sparks,</li> <li>- When one knob is pressed, the ignition plugs spark on all the burners at once,</li> <li>- There are sparks but the burners do not light.</li> </ul> </li> </ul>	<ul style="list-style-type: none"> <li>- Check the electrical connection of the hob.</li> <li>- Check that the ignition plugs are clean.</li> <li>- Check that the burners are correctly assembled and clean.</li> <li>- This is normal. The ignition function is centralised and controls all the burners simultaneously.</li> <li>- Check that the gas supply has been turned on.</li> <li>- If your gas is supplied by a bottle or a tank, check that these are not empty.</li> <li>- If you have just installed the hob or changed the bottle of gas, keep the knob pressed down and turned to the highest position for 3 to 5 seconds until the gas reaches the burners.</li> <li>Light the burner by placing the knob between maximum  and minimum gas flow .</li> </ul>
<ul style="list-style-type: none"> <li>• <b>The retarder (reduced flow) on the burners does not stay alight or else is too strong.</b></li> </ul>	<ul style="list-style-type: none"> <li>Check that the injectors fitted correspond to the gas being used (see the markings on the injectors: chapter, "Gas characteristics" at the end of part one).</li> <li>Remember: the hob comes pre-adjusted for mains gas (natural gas).</li> <li>- Check that the retarders have been adjusted correctly (see the chapter "Changing the gas" in instruction manual).</li> </ul>



● DEFECTS IN APPEARANCE THAT DO NOT LEAD TO THE NON-FUNCTIONING OF THE HOB OR THE IMPOSSIBILITY OF USING IT ARE NOT COVERED BY THE GUARANTEE.



**PRECAUTIONS:** Do not arrange *cleaning products* or *flammable products* (aerosols or recipients under pressure) in the support furniture under the cooking hob. This also applies to paper and cookery books.

# Gas rating

Appliance designed for installation in AUSTRALIA :	AUSTRALIA	
	LPG 2.75 kPa	NATURAL GAS 1 kPa
<b>AUXILIARY BURNER</b> Indicator marked on injector Heat output/HCP (MJ/hr)	50 3.4	80 3.4
<b>FAST BURNER</b> Indicator marked on injector Heat output/HCP (MJ/hr)	78 7.6	133 8.0
<b>SEMI-FAST BURNER</b> Indicator marked on injector Heat output/HCP (MJ/hr)	62 4.9	107 5.4
<b>DOUBLE CROWN BURNER</b> Indicator marked on injector Heat output/HCP (MJ/hr)	95 11.5	160 12

## NATURAL GAS

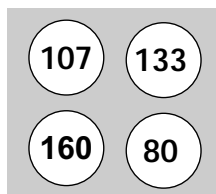

## LPG

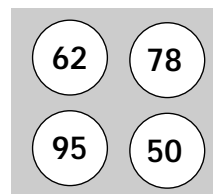

DEPENDING ON MODEL

	PREPARATIONS	TIME	DOUBLE CROWN	EXTRA FAST	FAST	SEMI-FAST	AUXILIARY
SOUPS	<i>BROTHS THICK SOUPS</i>	8-10 MINUTES	X	X	X		
FISH	<i>COURT-BOUILLON GRILLED</i>	8-10 MINUTES 8-10 MINUTES	X	X X			
SAUCES	<i>HOLLANDAISE, BEARNAISE BECHAMEL, AURORE</i>	10 MINUTES				X X	X X
VEGETABLES	<i>ENDIVES, SPINACH PEAS IN SAUCE PROVENCE TOMATOES FRIED POTATOES PASTA</i>	25-30 MINUTES 15-20 MINUTES	X   X	X X X X	X X X		
MEAT	<i>Steak BLANQUETTE, OSSO-BUCCO FRIED ESCALOPE TOURNEDOS (CAST IRON GRILL)</i>	90 MINUTES 10-12 MINUTES 10 MINUTES	X  X	X X X			
FRYING	<i>CHIPS FRITTERS</i>		X X	X X			
DESERTS	<i>RICE PUDDING STEWED FRUIT PANCAKES CHOCOLATE CUSTARD COFFEE (SMALL COFFEE-POT)</i>	25 MINUTES  3-4 MINUTES 3-4 MINUTES 10 MINUTES		X X	X	X X  X	X   X X

## Part 2: After-Sales Service

### WARRANTY AND SERVICE



#### DOMESTIC WARRANTY - Full Five Year Warranty

In addition to all statutory rights which you, the Consumer, have under the relevant laws in respect of this appliance, during the first five years of ownership as the original purchaser of the Kleenmaid appliance, we guarantee that any fault caused by faulty material or workmanship becoming apparent will be rectified free of charge for parts and labour, provided that all service is performed during normal working hours by Kleenmaid or their designated Agents. Where the appliance is installed outside the normal servicing area of the above, the Purchaser must pay for the cost of transporting the appliance to and from the Agent or the Agent's travelling cost to and from the Purchaser's home.

#### COMMERCIAL WARRANTY - Full One Year Warranty

In addition to all statutory rights which you, the Consumer, have under the relevant laws in respect of this appliance, during your first one year of ownership as the original purchaser of the Kleenmaid appliance, we guarantee that any fault caused by faulty material or workmanship becoming apparent, will be rectified free of charge for parts and labour, provided that all service is performed during normal working hours by Kleenmaid or their designated Agents. Where the appliance is installed outside the normal servicing area of the above, the Purchaser must pay for the cost of transporting the appliance to and from the Agent of the Agent's travelling cost to and from the Purchaser's home.

#### WHAT THESE WARRANTIES DO NOT COVER

We are not responsible for any damage or malfunction unless caused by a defect in material or workmanship. This includes, but is not limited to abuse, misuse, improper installation and transportation damage. We are not responsible for any consequential damages from any malfunction.

#### WARRANTY DOES NOT COVER REPLACEMENT OF LIGHT GLOBES OR GLASS BREAKAGE DUE TO IMPACT

In case of fractured glass do not use your appliance.

#### WARRANTY REGISTRATION

Please complete the enclosed warranty card and retain it with your receipt of purchase.

#### SERVICE ASSISTANCE

To assist you when phoning our Customer Call Centre number to arrange a service call please have the following details ready.

Model Number: .....

Date of Purchase: .....

Kleenmaid Store purchased from: .....

Date of installation: .....

**PLEASE NOTE: ALL SERVICING SHALL BE CARRIED OUT ONLY BY AUTHORISED PERSONNEL.**

**KLEENMAID APPLIANCE SERVICE & SPARE PARTS**

**CONTACT NUMBER 1300 652 100**

**C**ongratulations on the purchase of your new appliance. This appliance has been designed and manufactured to give you years of reliable performance. For best results, carefully read the instructions on how to install your new appliance. Correct installation will avoid delays and unnecessary service calls.

Once installation is complete, read this booklet carefully and get to know the controls and the features of your new appliance.

For appliance please phone

1300 652 100

Kleenmaid St George Store

131308

We reserve the right to alter the specifications with no influence on the operation of the appliance. This instruction manual cannot be reason for claim.

Other products in Kleenmaid St George  
range of world's best appliances:

Washers

Dryers

Dishwashers

Ovens

Cooktops

Rangehoods

Sinks

Waste Disposals

Taps

Cookware

Refrigerators

Freezers

Vacuum Cleaners

**For sales information on the full range of quality kitchen and laundry  
appliances, phone 13 13 08.**

**For service related enquires, phone 1300 652 100**