

*Instructions for installing  
and using  
your vitroceramic hob*

**CH800CE**

***Brandt***

*hob  
reference HNH 25 B1E*

You have just bought a new cooking hob; thank you for choosing Brandt.

All our hobs have been designed for years of use in your kitchen and to give you full satisfaction. Our priorities are ease of use, aesthetic appearance and reliability.

Nowadays, more than ever, whatever your demands and your tastes, you will find that Brandt provides you with household appliances which will make your life easier and more beautiful every day for years to come.

Your interest in our products is our strongest motivation. For you, Brandt must remain a synonym for quality, economy and performance. That is why we want to stay close to you and encourage dialogue.

Listening to you, informing you, advising you - that's what our consumer service is all about.

Thank you for putting your trust in us.

Our reward will be your satisfaction, which will fully justify our slogan:

"Brandt innovations you need".

**Brandt**

## PART 1 FOR THE INSTALLER

<u>WHAT YOUR HOB LOOKS LIKE</u>	<u>P. 3</u>
<u>HOW A VITRO-CERAMIC HOB WORKS</u>	<u>P. 3</u>
<u>GENERAL INFORMATIONS</u>	<u>P. 4</u>
<u>FITTING INTO A UNIT</u>	<u>P. 4</u>
<u>CHOOSING YOUR INSTALLATION</u>	<u>P. 5</u>
<u>CHARACTERISTICS</u>	<u>P. 6</u>
<u>HOW TO CONNECT YOUR COOKING HOB</u>	<u>P. 6</u>

## PART 2 FOR THE USER

<u>HOW TO USE THE ZONES</u>	<u>P. 7</u>
<u>SAFETY</u>	<u>P. 8</u>
<u>QUESTIONS AND ANSWERS</u>	<u>P. 8</u>
<u>HOW TO CLEAN YOUR COOKING HOB</u>	<u>P. 9</u>
<u>PRECAUTIONS FOR USE</u>	<u>P. 10</u>
<u>COOKING TIPS AND GUIDE</u>	<u>P. 11-12</u>

### Look out for



**tips**



**warnings**



**things to read**



**contacts**



These hobs have been designed for private use in the home.

**Please read these instructions before installing and using your hob.**

With a view to the constant improvement of our products, we reserve the right to make any changes in their technical, functional or aesthetic characteristics as a result of technical evolution.

These hobs are designed exclusively for the cooking of drinks and foodstuffs.

These products do not contain any asbestos-based component parts.

# Presentation

## WHAT YOUR HOB LOOKS LIKE

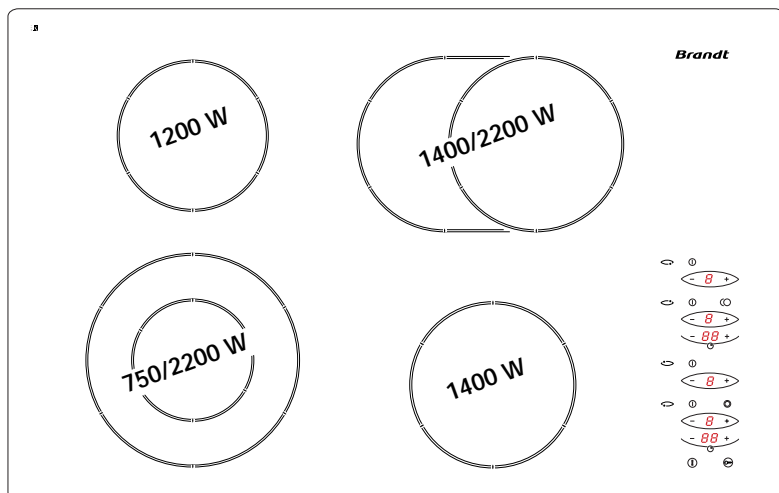

3

Indicator (1 to 9) of power required for each heating zone.



Lock indicator



Lock key



general stop key



Adjustment of power (+ or -) for each heating zone.



On/off control for each heating zone.



Symbol indicating the heating zone on the hob.



start key for the additional zone

H

Residual heat indicator



Timer setting button

## HOW A VITRO-CERAMIC HOB WORKS

The FAST RADIANT rings are comprised of a ribbon heating element fitted with a temperature limiter. These rings transmit heat by conduction to the vitro-ceramic glass, to the pan, and then to the food.

# Part 1: For the installer

## GENERAL INFORMATION

**FITTING SHOULD NORMALLY ONLY BE CARRIED OUT BY A QUALIFIED FITTER OR TECHNICIAN.**



Please keep to the following points most carefully :

- The hob should not be fitted above a washing machine, a fridge or a freezer.
- Wall surfaces above the work surface and in the immediate vicinity of the cooking hob must be heat resistant.
- Laminated surfaces and the adhesive used for fixing them must be heat resistant in order to avoid any damage.
- **Protection of cut-outs:**  
The chipboard used for work surfaces swells relatively quickly when in contact with dampness. Apply a varnish or a special glue to the edges of the cut-out to protect them from dampness or condensation which may occur underneath the work surface underneath the table.
- **Protection against overheating - type Y - to CEI 335-2-6.**

## FITTING INTO A UNIT

- Cut a hole in the work surface to the required size. The measurement of at least 40 mm should be measured from the wall and the sides (rear and/or sides).
- The cooking hob should be fitted into the top surface of a unit at least 3 cm thick, in heat-resistant material or surfaced with heat-resistant material.
- To fix the hob, use the fasteners which you will find in the wallet .
- Stick the seal under the hob to ensure a watertight seal between the hob and the work surface (see fig. below).



So that cooking utensils can be used easily, there should be no unit or vertical surface within 30 cm of the cooking hob.

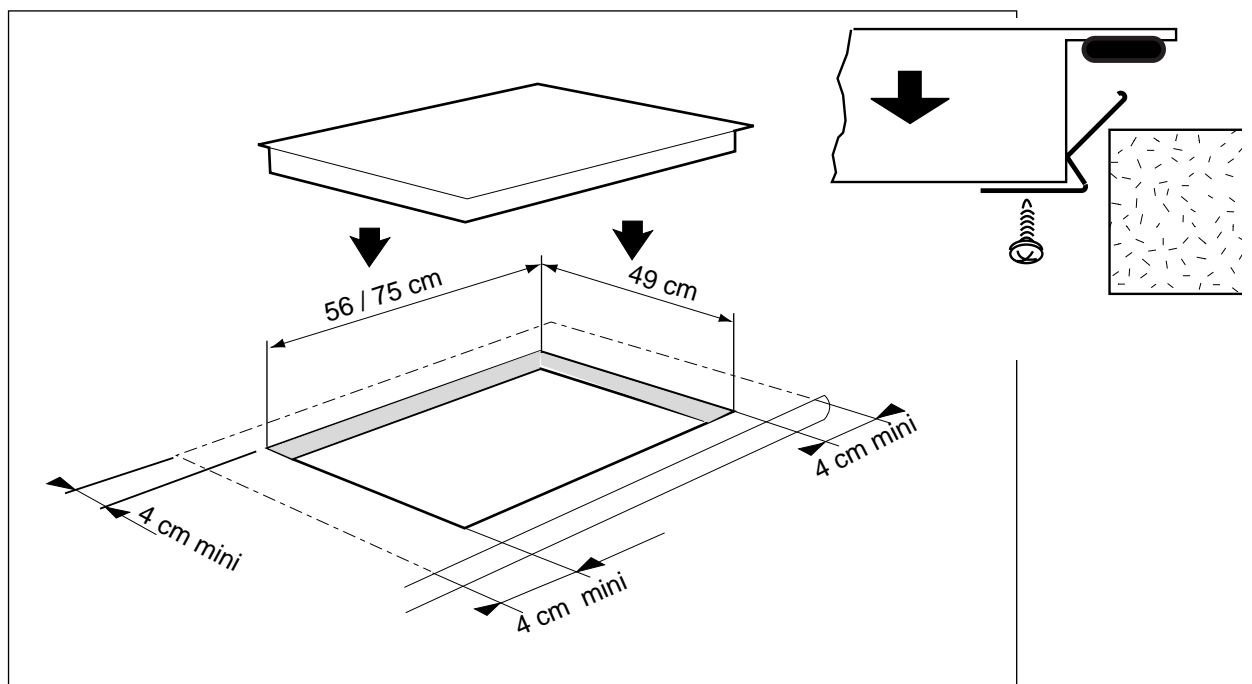

# Part 1: For the installer

## ● CHOOSING YOUR INSTALLATION

- over an empty unit or drawer
- over an oven

### Over an empty unit or drawer

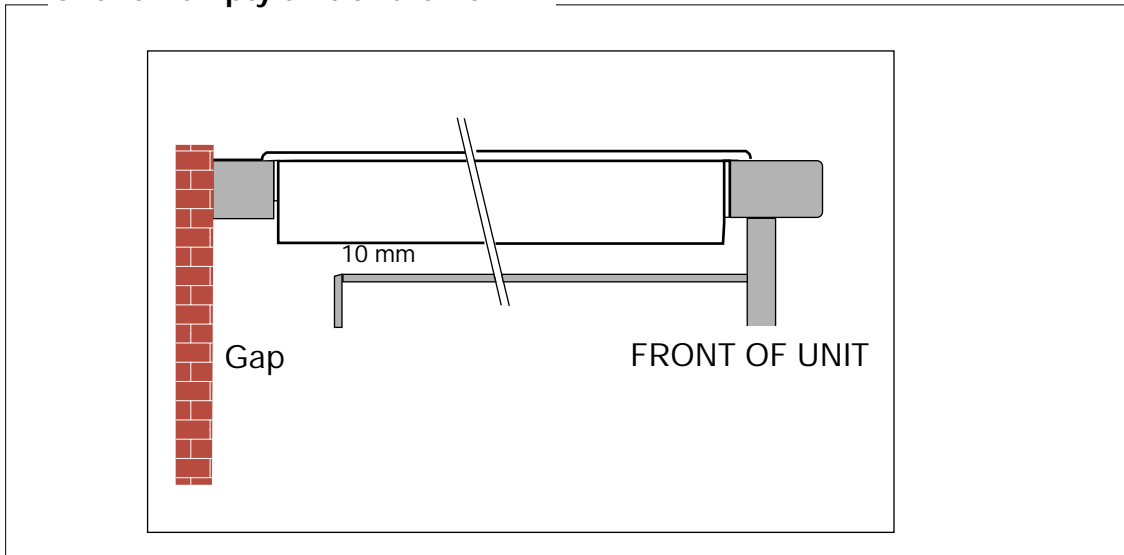

### Over an oven

The hob may be fitted directly into the work surface over an oven in the upper position (minimum distance 10 mm).

Vitro-electronic hobs are fitted with **thermal security devices** for protection in the event of overheating; these put the hob on "**hold**" while it cools down.

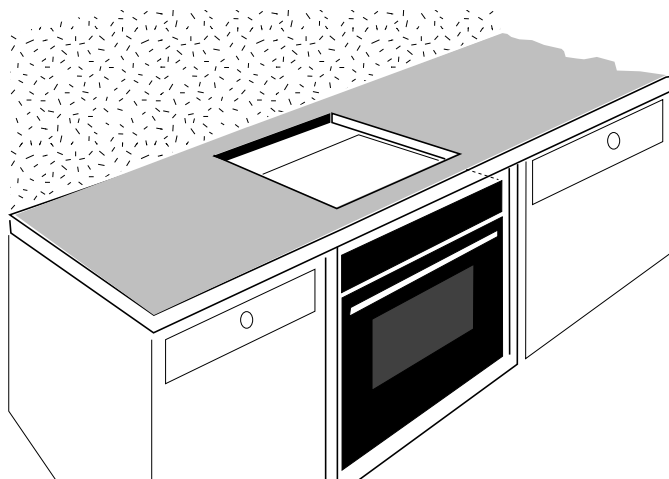

# Part 1: For the installer

## ● CHARACTERISTICS

### HNH25B

Operating voltage.....	230 V~ 50 Hz
Total electrical power absorbed.....	7000 W
Dimensions for cut-out in unit.....width depth	750mm 490 mm
Max. space taken up under the work surface.....	41 mm
Overall dimensions under the work surface.....width depth	743 mm 488 mm
Overall dimensions above the work surface.....width depth height	770 mm 510 mm 4mm
Weight .....	14 Kg
Constructor .....	N°419

## ● HOW TO CONNECT YOUR COOKING HOB TO THE POWER SUPPLY

These hobs must be connected to the electricity supply by means of:

- A 05 WF-type power cable with 3, 2.5 sq.mm. conductors, or 5 1.5 sq.mm. conductors (including 1 earth wire - green/yellow);
- A plug which complies with publication CEI 83 or an omnipolar cutout device with a contacts gap of at least 3 mm.



When your hob is first connected, or after a lengthy power failure, coded lights appear on the control panel. These disappear automatically after about 30 seconds, or as soon as any of the controls are touched. This display is perfectly normal; if necessary, it provides information for your After-Sales Service.

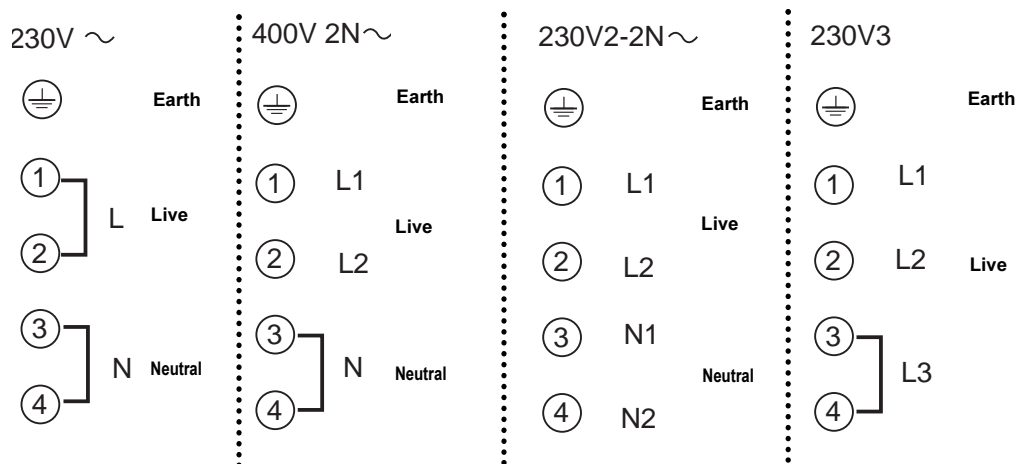

# Part 2: For the user

## ● HOW TO USE THE COOKING ZONES

### SWITCHING ON

Look for the controls which correspond to the zone where you have put your pan.

- Press the  key.

The power indicator shows 0, the hob is switched on.

- **Adjust the heating power you want**  
- For a fast adjustment, keep your finger on the - or + control.

After you have pressed the  key, if you do not select a power level the instruction will be automatically cancelled after 10 seconds.

- **Adjust the power during cooking**  
You can adjust the heating power from 1 to 9 at any time during cooking using the + keys.

### TURNING A HEATING ZONE OFF

- Press the  key for the appropriate zone.

### TIMER SETTING BUTTON (FROM 1 TO 99 MINUTES)



Depress the + or -  button to display the desired time setting.  
For rapid adjustment, keep your finger on the + or - button.  
At any time during the cooking the power can be modified by depressing the + or - button. At the end of the pre-set time, the heating area is

extinguished and a bleep for a few minutes informs the user.

#### **Stop the timer during cooking.**

Depress the (-) button until 0 to switch off the timer (The heating area continues to function without the timer)

### USING THE ADDITIONAL ZONE

- Press the  or  key to switch on the additional zone.

The additional heating zone can not be switched on without the main cooking zone.

Adjust the heating power if necessary.

- **To stop the additional zone** press one more the  or  key

Adjust the heating power if necessary.

### LOCKING

#### **Key to lock / unlock the controls.**

This key locks the controls while they are in use or during cleaning.

**To lock:** Press the key for 3 seconds,

There is a bleeping sound and the lock indicator lights up, confirming that the operation has been registered.

The controls can be locked when the rings are off, or while they are in use (current instructions will still apply and the settings indicated will remain active).

**To unlock:** Press on the key until the light goes out (approx. 1 or 2 seconds) and 2 bleeps sound, confirming that the operation has been registered.

## Part 2: For the user



**IMPORTANT** : If you have an oven underneath your cooking hob (see possible configurations for building in), the thermal security devices will not allow the hob to be used at the same time as the oven is being cleaned by pyrolysis.

### SECURITY DEVICE ON THE VITRO-CERAMIC HEATING AREA

- **Residual heat indicator**

The indicator displays **H** :

**Do not touch the corresponding heating zones - you could be burned.**

After a prolonged power failure, there may be a display on the control panel; this will go out as soon as any key is touched. The cooking zones may nevertheless still be very hot.

- **Thermal cutout device**

The indicator displays **E** :

To avoid any risk of damage in certain cases of intensive use, the security device will limit the operation of your hob. When the display goes out (approx. 30 mins.), you will be able to use your hob once more.

- **Security device on the controls**

If a pan (or anything else) covers the keys for more than 10 seconds, the power supply to the cooking zones may cut out.

- **Note**

When your hob is first connected, a display may appear on the control panel. This will go out of its own accord after 30 seconds or after touching any of the controls.

This is quite normal; if necessary, it provides information for your After-Sales Service.

The user of the hob should disregard it.

QUESTIONS	ANSWERS
<ul style="list-style-type: none"><li>• <i>The hob isn't working. There is no display.</i></li></ul>	<p>There is no power supply (faulty supply or connection). Check the fuses and the electricity cut out switch.</p> <p> - The electronic circuit is not working properly: <b>Call the After-Sales Service.</b></p>
<ul style="list-style-type: none"><li>• <i>When the hob is turned on, the power to it cuts out.</i></li></ul>	<p>- <i>The connection to the hob is faulty.</i> <i>Check the connection or that the hob has been properly installed</i></p>

# Part 2: For the user

## HOW TO CLEAN YOUR HOB



Never clean your hob while it is on. Turn all the controls to 0 first.

TYPE OF DIRT	WHAT TO DO	OTHER PRODUCTS TO USE
Slight	Soak the area to be cleaned with hot water, then wipe.	Ordinary sponge
Accumulation of burner-on grime	Soak the area to be cleaned with hot water, wipe with the abrasive side of a sponge if necessary, then wipe.	Ordinary sponge
Rings and lime scale	<ul style="list-style-type: none"> <li>Apply hot white vinegar to the mark, leave to work, then wipe with a soft cloth.</li> <li>Or use a special product available in the shops.</li> </ul>	Special paste for vitro-ceramic glass
Burnt-on sugary food, melted aluminium or plastic	<ul style="list-style-type: none"> <li>Use a special scraper for glass surfaces to remove as much residue as possible</li> <li>Or apply a special product for vitro-ceramic glass, preferably one which contains silicones (to protect the glass).</li> </ul>	Special product for vitro-ceramic glass



If sugar, jam, jelly, etc boils over, the spills should be scraped off the hot cooking zone immediately to prevent damage to the surface of the hob.

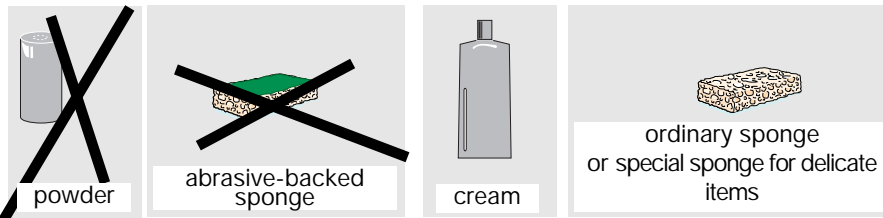

## ACCESSORIES

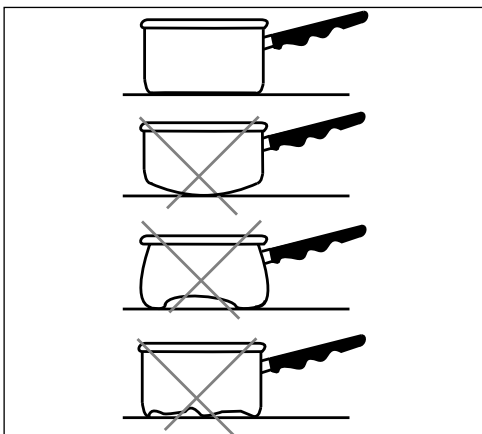

- Use pans designed for use on an electric cooker.
  - Use pans with flat bases which remain in contact with the surface of the ring:
    - in stainless steel with a thick three-ply or "sandwich" base.
    - in aluminium with a thick, smooth base.
    - in enamelled steel.
- Pans with very rough bases may pick up and carry material which could stain or scratch the hob.

---

## Part 2: For the user

---

### ● PRECAUTIONS FOR USE

---

- The vitro-ceramic surface is very tough, but it is not unbreakable; don't bang pans down onto it.
- Pan bases which are very rough may trap and carry substances which may mark or scratch the hob.
- Avoid friction; over a period of time, this may damage the pattern on the vitro-ceramic top.  
**As these faults do not stop the hob working or render it unfit for use, they are not covered by the guarantee.**  
**Nothing should ever be left lying on the hob.**
- Do not store *CLEANING PRODUCTS* or *FLAMMABLE ITEMS* in the unit underneath your cooking hob.
- When plugging electric appliances into sockets near the hob, make sure that the flex does not come into contact with a heating zone.
- It is not a good idea to leave an empty pan on a heating zone.
- Pans should be placed in the centre of the heating zone.
- Never heat up a sealed tin of food, as it may explode. This of course applies to all cooking methods.

### ● COOKING TIPS FOR USING THE VITRO-CERAMIC HEATING ZONE

---

- Never leave a pan containing hot oil or fat on any of the cooking zones without supervision.
- Don't put any plastic items or aluminium foil on the cooking surfaces while they are still hot.
- You will obtain the best result by using a pan with a diameter close to the size of the ring marked on the glass top.
- Wipe the outside base of the pan before using it on the vitro-radiant heating zone.
- **Automatic adjustment of rings:**  
**The radiant ring adjusts itself automatically**, it comes on and goes off in order to maintain the power selected. Thus the temperature remains constantly suited to the food you are cooking.  
  
Lastly, the frequency of adjustment varies according to the power selected.

---

# Part 2: For the user

---

## ● COOKING TIPS

---



**Cooking will be a pleasure if you stick to a few rules and look after your hob.**

### Cooking tips

Green vegetables (spinach, broccoli, sorrel, etc) or vegetables rich in sulphur compounds (cabbage, onions, etc) should be cooked without a lid in plenty of boiling water; they will cook more quickly, and will keep their green colour (some vegetables only), vitamin and minerals content.

Pasta, rice, cereals, etc absorb water during cooking and increase in volume; cook them in plenty of boiling salted water in order to dilute the starch they contain. Make sure you use a sufficiently large pan to avoid boiling over; cook without a lid (there is a risk of foaming and therefore of the pan boiling over).

Mushrooms should be poached in a small quantity of boiling water, with salt, butter and lemon juice.

### Hints

As soon as the water boils, turn the cooking zones down to a lower setting; this will help prevent pans boiling over.

Whenever possible, use a lid on saucepans; this will help save energy.

### Looking after your pans

- Stainless steel pans :

Appearance of white marks :

Cause : salt added to cold water.

Solution : add salt when the water boils.

Appearance of specks :

Cause : hard water.

Solution : boil diluted vinegar in the pan, then rinse and dry.

Abrasive products should never be used on stainless steel pans. They should be washed with a sponge.

Burned food stuck to the bottom of the pan :

Cause : temperature too high.

Solution : leave the pan to soak, or boil soapy water in it (1 part washing-up liquid to 10 parts of water).

Cast-iron pans should only be cleaned with a sponge or nylon brush or a non-abrasive washing-up product. If marks remain on the base, don't try to rub them off; boil a litre of water plus a glassful of bleach in the pan. Wipe with a little vinegar to regain the pan's shine. This also works for colour-enamelled cast iron. For "matt black" items, use vinegar instead of bleach, then oil carefully and wipe with kitchen roll.



Should a crack appear in the surface of the glass, disconnect the appliance from the electricity supply immediately by removing the fuses or using the circuit-breaker  
**Do not use any part of the hob before the vitro-ceramic top has been changed.**

## COOKING GUIDE FOR USING THE VITRO-CERAMIC HEATING ZONE

- **A higher setting is needed when :**
  - your pan contains a large quantity of food;
  - there is no lid on the pan;
  - you use a glass or ceramic pan.
- **A lower setting is needed when :**
  - you are cooking foods which tend to burn easily (start on a lower setting than the one shown in the table below - you can increase the setting subsequently if necessary);
  - the pan boils over (take the lid off or remove the pan, then turn the setting down).
- **Energy saving :**

To finish cooking, press the "stop" control and leave the pan on the hob to make use of the residual heat (thereby saving energy).  
Use a lid as often as possible in order to reduce heat lost by evaporation.

PREPARATIONS		VERY FAST		FAST	MEDIUM		SLOW	SIMMERING RE-HEATING		KEEPING WARM
		9	8	7	6	5	4	3	2	1
SOUPS	THIN SOUPS THICK SOUPS					5	4			
FISH	COURT-BOUILLON DEEP FRIED			7		5				
SAUCES	THICK, FLOUR-BASED SAUCES BUTTERY SAUCES CONTAINING EGGS (BÉARNAISE, HOLLANDAISE)							3	2	
VEGETABLES	SPINACH PULSES, BOILED POTATOES CARROTS SAUTÉ POTATOES FROZEN VEGETABLES				6 →	5		3		
					6 →	5	4			
					6 →	5	4			
MEAT	THIN CUTS OF MEAT FRIED STEAK GRILLED MEAT (USING CAST-IRON GRILL-PAN)	9	8							
DEEP FRYING	FROZEN CHIPS FRESH CHIPS	9								
OTHER TYPES OF COOKING	PRESSURE COOKER STEWED FRUIT PANCAKES CUSTARD TO MELT CHOCOLATE JAM MILK FRIED EGGS PASTA RE-HEATING GLASS JARS OF BABY FOOD (IN A PAN OF WATER) STEWES RICE PUDDING  KEEPING FOOD WARM	9 →	8				4		2	1
				7			4			
				7			4			
							4		2	
										1

To obtain full satisfaction, follow the examples in the guide above, bearing in mind that settings 9 and 8 are maximum positions and should only be used for deep frying and bringing up to the boil quickly.



**When cooking, never use kitchen foil and never put items wrapped in kitchen foil straight onto the hob.**

**The aluminium would melt and do irreparable damage to your appliance.**