

Cooking collection

Instructions for fitting and using your induction and Warranty Details

ICK60 - 600 mm Induction Cooktop

 **Kleenmaid**
The best you can own

Congratulations on the purchase of your new appliance.

This appliance has been designed and manufactured to give you years of reliable performance.

For best results, carefully read the instructions on how to install your new appliance. Correct installation will avoid delays and unnecessary service calls.

Once installation is complete, read this booklet carefully and get to know the controls and the features of your new appliance.

We reserve the right to alter the specifications with no influence on the operation of the appliance. This instruction manual cannot be reason for a claim.

As part of our commitment to constantly improving our products, we reserve the right to make changes to them based on technological advances to their technical, functional and/or aesthetic properties.

Young children should be supervised to ensure that they do not play with the appliance.

The appliance is not intended for use by young children or infirm person without supervision.

If the supply cord is damaged, it must be replaced by the manufacturer or its service agent or a similarly qualified person in order to avoid hazard.



Attention

Before installing and using your appliance, please carefully read this Guide to Installation and Use, which will allow you to quickly familiarise yourself with its operation.

TABLE OF CONTENTS

- Safety Guidelines _____ 04
- Description of Your Appliance _____ 05
- Environmental Protection _____ 05

- 1 / INSTALLING YOUR APPLIANCE**
- Proper positioning _____ 06
- Building in _____ 06
- Hook-up _____ 07

- 2 / USING YOUR APPLIANCE**
- Description of the top _____ 09
- Cookware for induction _____ 10
- Which cooking zone should you use based on your cookware? _____ 10
- Description of control panel _____ 11
- Powering on _____ 11
- Adjusting the power _____ 11
- Setting the timers _____ 11
- Using the "child safety device" _____ 11
- Safeties during operation _____ 12

- 3 / DAILY CARE OF YOUR APPLIANCE**
- Protecting your appliance _____ 13
- Maintaining your appliance _____ 13

- 4 / SPECIAL MESSAGES, DIFFICULTIES**
- During initial use _____ 14
- When powering on _____ 14
- During operation _____ 14

- 5 / COOKING CHART**
- Cooking chart for food types _____ 15

- **SAFETY GUIDELINES**

We have designed this cooking hob for use by private persons in their homes.

These cooking hobs are meant to be used exclusively for cooking beverages and food-stuffs and do not contain any asbestos-based materials.

- **Residual heat**

A cooking zone can remain hot for several minutes after use.

An "H" is displayed during this period.

Avoid touching the hot areas during this time.

- **Child safety device**

Your hob is equipped with a child safety device that locks its operation after use or during cooking (See "Using the Child Safety Device" section).

Do not forget to unlock it before using the hob again.

- **For users of pacemakers and active implants**

The functioning of the hob conforms to current electromagnetic interference standards and thus is in total compliance with legal requirements (89/336/CEE directives).

In order to avoid interference between your cooking hob and a pacemaker, your pacemaker must be designed and programmed in compliance with the regulations that apply to it.

Consequently, we can only guarantee that our own product is compliant.

With regard to the compliance of the pacemaker or any potential incompatibility, you can obtain information from the manufacturer or your attending physician.



Electrical Danger

Ensure that the power cables of any electrical appliances plugged in close to the hob are not in contact with the cooking zones.

If a crack appears in the glass worktop, immediately disconnect your appliance to avoid the risk of electric shock.

To do this, remove the fuses or use the circuit breaker.

Do not use your hob until you have replaced the glass worktop.

• **DESCRIPTION OF YOUR APPLIANCE**

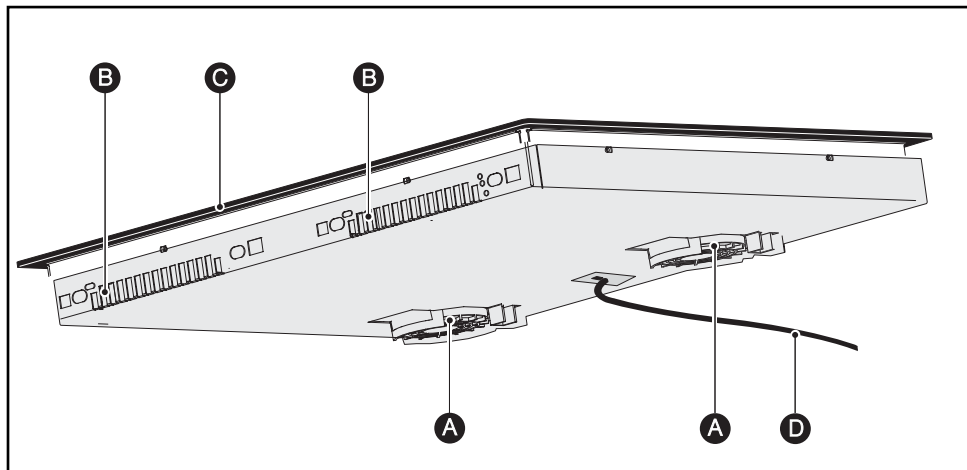

- **A** Air intake
- **B** Air outlet
- **C** Vitroceramic glass
- **D** Power cord

• **ENVIRONMENTAL PROTECTION**

The packing materials can be recycled.

Dispose of them in containers provided for this purpose based on their individual recycling symbols.

Used appliances should be disposed of in compliance with the regulations in effect in your place of residence.

1 / INSTALLING YOUR APPLIANCE

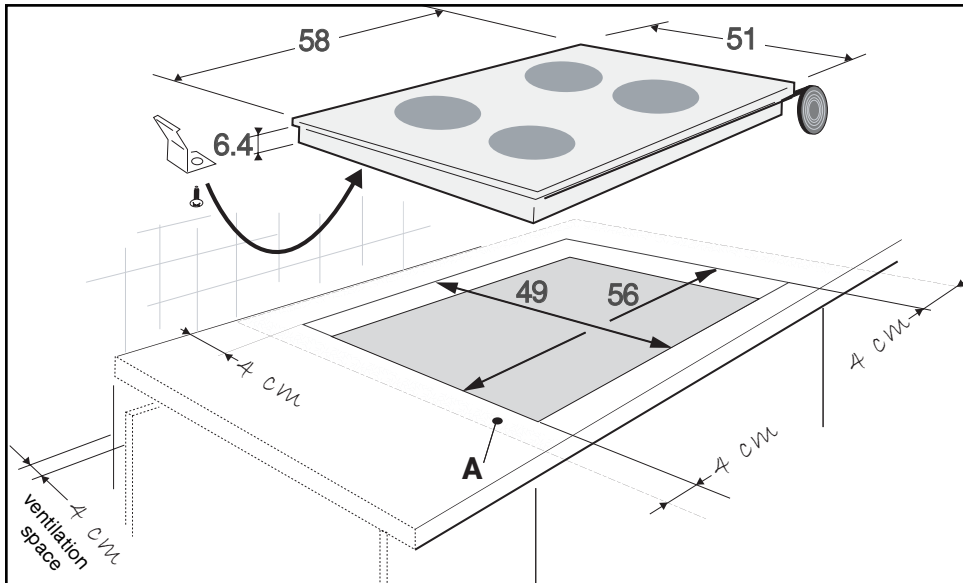

• PROPER POSITIONING

Your appliance should be positioned so that the plug-in unit is accessible.

The distance between the edge of your appliance and the side and rear walls (or partitions) must be at least four centimetres (area A).

Your appliance can be easily integrated above a cabinet, an oven or a build-in-ready household appliance. You must simply ensure that the air intakes and air outlets are clear (See "Description of Your Appliance" section).

• BUILD-IN

Follow the diagram above.

Glue the foam seal underneath your appliance by following the outline of the worktop upon which your appliance will rest. This will allow you to achieve an airtight seal with the worktop.

Attach the clips to the hob.



Tip

If your oven is located below your hob, the hob's thermal safety measures forbid the simultaneous use of the hob and the pyrolysis program of your oven.

Your hob is equipped with an anti-overheating safety device.

This safety can be activated, for example, when the hob is installed over an oven that is not sufficiently insulated. If this occurs, a series of small lines appear in the control panel. In this case, we recommend that you increase the ventilation of your hob by creating an opening in the side of your cabinet (8 cm x 5 cm)



Warning

You must ensure that the air intakes located under your cooking appliance remain clear at all times.

For all types of installation, your induction hob needs proper ventilation.

1 / INSTALLING YOUR APPLIANCE

• INSTALLATION/VENTILATION REQUIREMENTS

When installing an induction hob above an underbench oven, cupboard or drawer unit, the following ventilation requirements must be observed:

- Heat Shield (heat resistant material, eg. melamine timber veneer) is to be positioned at least 50mm below hob.
- Cooktop must be isolated from under-bench area. Heat Shield edges to be sealed to surrounding surfaces
- A Vertical Divider (heat resistant material, eg. melamine timber veneer) is to be positioned between the Heat Shield and the underside of the hob approximately 300mm from back of cupboard. Length of Vertical Divider needs to be equal to

width of Heat Shield. Vertical Division must fit tightly and act as a barrier to air flowing back towards the cooling fan in hob (as per diagram).

- Ventilation holes must be drilled into side of adjoining cupboards to allow fresh air supply to cooktop.
- When installing into a granite worktop, drill holes below worktop (as per diagram). Insulation kit as shown in owners manual is not required when installation is carried out according to these specifications (this is not supplied by Kleenmaid).

WARNING: The induction cooktop cannot be installed above a fridge, dishwasher or washing machine.

Incorrect installation or failure to follow instructions may result in premature failure of cooktop and will void warranty.

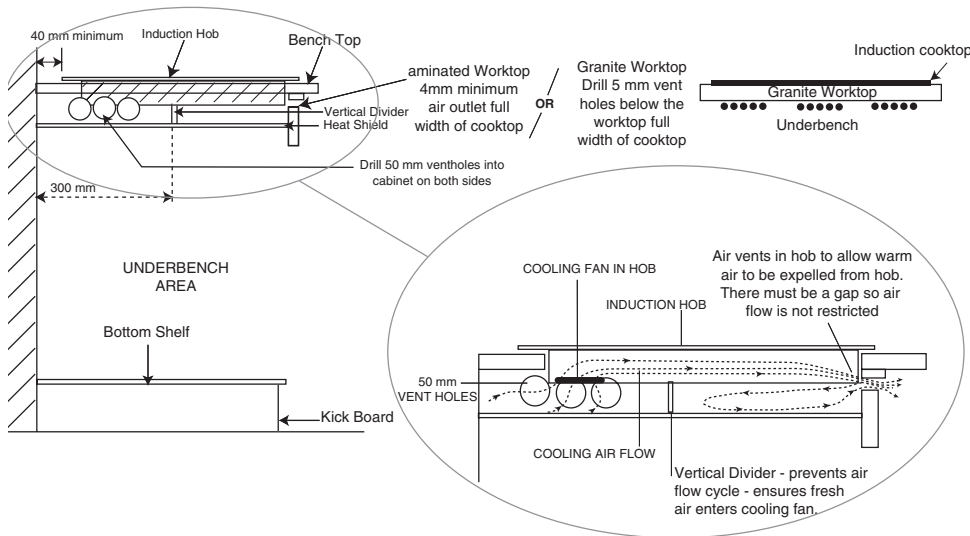

1 / INSTALLING YOUR APPLIANCE

• HOOK-UP

• 220-240 V monophasic hook-up 32-amp fuse.

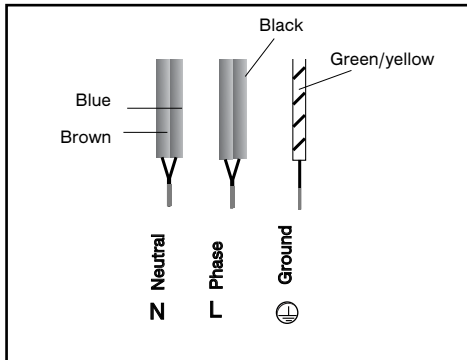

These hobs must be connected to the power grid via an electrical outlet that complies with EIC publication 60083 or an all-pole cut-off device that complies with installation regulations in effect.

When power is first supplied to your hob, or after an extended power outage, an indicator light will appear on the control panel. It automatically disappears after approximately 30 seconds, or as soon as any touch control on the control panel is pressed. This display is normal and, if needed, serves as an indication to the after-sales service staff. In all cases, the user of the hob should disregard it.



Warning

If the power cable is damaged, it should be replaced by the manufacturer, its after-sales service department or by a person with similar qualifications to avoid danger.

• 400 V 2N triphase hook-up 16-amp fuse.

Separate the two phase wires (L1 and L2) before hooking up.

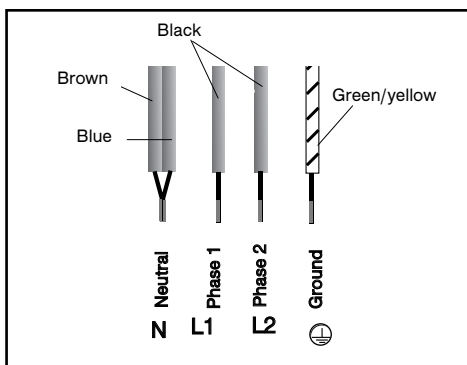

For a 400 V 2N triphase hook-up, if your hob malfunctions, check that the neutral conductor is properly connected.

2 / USING YOUR APPLIANCE

- **DESCRIPTION OF THE TOP**

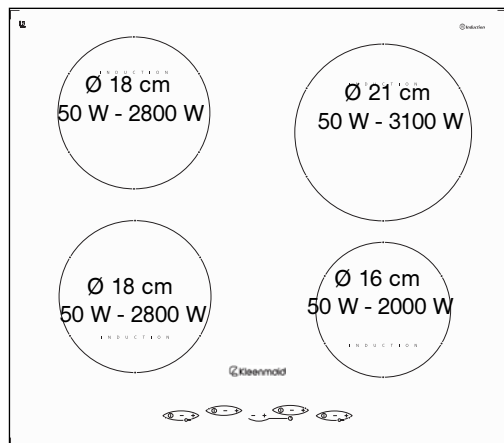

ICK60

2 / USING YOUR APPLIANCE

• COOKWARE FOR INDUCTION

• The induction principle

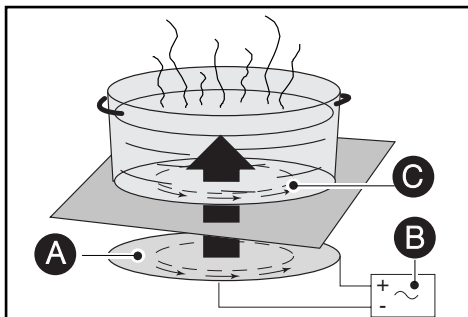

- A** Inductor
- B** Electronic board
- C** Induced electric current

The principle of induction is based on a magnetic phenomenon.

When you place your cookware on a cooking zone and you turn it on, the electronic boards in your cooking hob produce "induced" currents in the bottom of the cookware and instantly raise its temperature. This heat is then transferred to the food, which is simmered or seared depending on your settings.

• Cookware

Most cookware is compatible with induction. Only glass, terra cotta, aluminium without a special finish on the bottom, copper and some non-magnetic stainless steels do not work with induction cooking.

We recommend that you select cookware with a thick, flat bottom. The heat will be distributed better and cooking will be more uniform.

• WHICH COOKING ZONE SHOULD YOU USE BASED ON YOUR COOKWARE?

Cooking zone	Cookware to use
16 cm	10 18 cm
18 cm	12 22 cm
21 cm	18 24 cm



Tip

To check the suitability of your cookware:

Place the vessel on a cooking zone at power level 4.

If the display remains on, your cookware is compatible.

If the display flashes, your cookware cannot be used with induction cooking.

You can also use a magnet to test the cookware.

If a magnet "sticks" to the bottom of the cookware, it is compatible with induction.

2 / USING YOUR APPLIANCE

• DESCRIPTION OF THE CONTROL PANEL

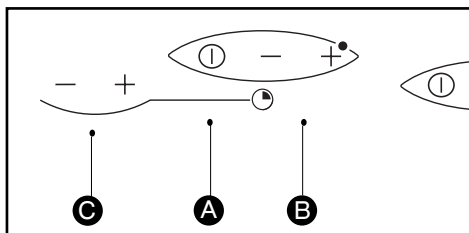

- A** Start/stop touch control.
- B** Power - + touch controls.
- C** Timer touch controls.

• POWERING ON

Press the start/stop touch control for the zone you want to use. A flashing "0" indicates that the zone is on. You can then choose the desired power level.

If you do not select a power level, the cooking zone will automatically shut off.

• ADJUSTING THE POWER

Press the + or - power touch controls.



Tip

For simultaneous use, favour the use of cooking zones located on opposite sides of the hob.

On the same side, the use of a cooking zone at maximum power results in an automatic limitation of the other cooking zone on that side, which is indicated in the power level display.

• SETTING THE TIMER

The timer functions when the cooking zone in question is in use.

To turn on the timer, press the - or + timer touch controls.

To adjust the timer setting, press the - or + touch controls.

To manually stop the timer, press until "0" is displayed.

When cooking is complete, "0" is displayed and a **beep** notifies you; to cancel these indications, press any touch control for the cooking zone in question.

Otherwise, these indications will automatically stop after approximately one minute.

• USING THE "CHILD SAFETY DEVICE"

Your cooking hob is equipped with a child safety device that locks its operation after use (e.g. so the hob can be cleaned) or during cooking (e.g. to guard your settings).

For safety reasons, the "off" touch control is always active and allows you to shut off a heating zone, even if it is locked.

• How do you lock the control panel?

Identify the touch controls used for locking (- +) located above a padlock icon.

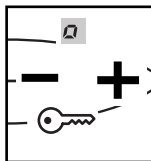

Press both of these touch controls simultaneously (- +) until the  symbol is displayed.

The display disappears after a few seconds.

Any attempt to adjust the touch control reactivates this display.

• How do you unlock the control panel?

Simultaneously press the - and + touch controls for locking until the locking icon disappears from the display.



Warning

Remember to unlock your hob before using it again (See the "Using the Child Safety Device" section).

2 / USING YOUR APPLIANCE

• SAFETY DURING OPERATION

• Residual heat

After intensive use, the cooking zone that you have just used can remain hot for several minutes.

An "H" is displayed during this period.

Avoid touching the hot areas during this time.

• Temperature limiter

Each cooking zone is equipped with a safety sensor that constantly monitors the temperature of the bottom of the cookware. In the event that an empty vessel is left on a cooking zone that is on, this sensor automatically adjusts the power output of the hob, thereby avoiding any risk of damage to the cookware or the hob.

• "Small Items" safety

A small object (such as a fork, a spoon, a ring, etc.) left alone on the hob is not detected as a piece of cookware.

The display flashes and no heat is produced.



Warning

Several small objects together on a cooking zone may be detected as cookware.

If the display remains on: power may be supplied and the objects may be heated.

• Protection against overflows

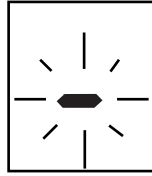

The hob may shut down (with the adjacent symbol in the display) automatically in any of these three situations:

- Overflow that spills onto the touch controls.
- Damp towel placed over the touch controls.
- Metallic object placed on the touch controls.

Clean the hob or remove the object, then begin cooking again.

• Auto-Stop system

If you forget to turn off a cooking zone, your hob is equipped with an "Auto-Stop system" safety measure that will automatically shut off the forgotten cooking zone after an amount of time pre-set at the factory (see the table below).

Power level used	The cooking zone automatically shuts off after
between 1 and 4	8 hours
between 5 and 7	2 hours
for 8 and 9	1 hour

In the event that this safety measure is triggered, the powering off of the cooking zone is indicated by an "A" displayed in the control panel. Simply pressing on any of the touch controls will cancel this display.

3 / DAILY CARE OF YOUR APPLIANCE

• **PROTECTING YOUR APPLIANCE**

Avoid hard shocks from cookware:

The vitroceramic glass worktop is very sturdy; however, it is not unbreakable.

Do not place any hot lids flat on your cooking hob. A suction effect may damage the vitroceramic surface.

Avoid dragging cookware across the surface, which may in the long-term result in the degradation of the decorative finish of the vitroceramic top.

Avoid placing cookware on the frame or cover (depending on the model).

Avoid using cookware with rough or bumpy bottoms: they can capture and transfer particles that may produce stains or scratches on your hob.

These defects that do not result in appliance malfunction or do not make it unsuitable for use are not covered by the warranty.

Do not store cleaning products or flammable products in the cabinet underneath your cooking hob.

Do not heat unopened canned goods; they may burst.

Of course, this precaution applies to all types of cooking.

Never use a sheet of aluminium for cooking. Never place items wrapped in aluminium foil or packaged in aluminium dishes on your cooking hob.

The aluminium will melt and permanently damage your cooking appliance.

Objects not intended for cooking should never be placed on the hob (risk of powering on, scratches, etc.).

Steam cleaning should never be used. The steam jet could damage your hob.

• **MAINTAINING YOUR APPLIANCE**

TYPE OF STAINS/SPOTS	USE	WHAT TO DO
Light.	Soft sponges.	Thoroughly moisten the zone to be cleaned with hot water, then wipe off.
Accumulation of baked-on soil. Overflow of sugary preparations, melted plastic.	Soft sponges. Scraper for glass.	Thoroughly moisten the zone to be cleaned with hot water. Use a scraper for glass to remove the large bits, follow with a sponge, and then wipe off.
Rings and hard water residue.	White spirit vinegar.	Apply warm white vinegar to the stain, let stand, then wipe with a soft cloth.
Shiny metallic streaks. Weekly maintenance.	Cleaning agent for vitroceramic glass.	Apply a cleaning agent for vitroceramic glass (preferable one with silicone for its protective properties) to the surface.



Cream



Special soft sponge for delicate dishes



Powder



Scouring sponge



4 / SPECIAL MESSAGES, DIFFICULTIES**• During initial use**

<i>YOU OBSERVE THAT:</i>	<i>POSSIBLE CAUSES:</i>	<i>WHAT SHOULD YOU DO:</i>
An indicator light appears.	Working normally.	Nothing.
Your installation blows a fuse.	The electrical hook-up of your hob is incorrect.	Verify the connections. See the "Hook-Up" section.
Only one side works.		
The hob produces an odour during the first cooking sessions.	New appliance.	Operate each cooking zone for 30 minutes with a saucepan full of water.

• When powering on

<i>YOU OBSERVE THAT:</i>	<i>POSSIBLE CAUSES:</i>	<i>WHAT SHOULD YOU DO:</i>
The hob is not working and the indicator lights on the control panel are not on.	The appliance is not receiving electricity. The electrical supply is defective or the hook-up is incorrect.	Inspect the electrical circuit breaker and fuses.
The table is not working and another message is displayed.	The electronic board is functioning poorly.	Call the After-Sales Service Department.

• During operation

<i>YOU OBSERVE THAT:</i>	<i>POSSIBLE CAUSES:</i>	<i>WHAT SHOULD YOU DO:</i>
The hob stops working and it emits a beep approximately every 10 seconds and a  or "F7" is displayed.	There was an overflow or an object is in contact with the control panel.	Clean the hob or remove the object, then begin cooking again.
A series of small  or "F7" is displayed.	The electronic boards heated up.	See "Built-In" section.
After turning on a heating zone, the indicator lights on the control panel continue to flash.	The cookware used is not suitable for induction or is less than 12 cm in diameter (10 cm for the 16-cm cooking zone).	See section on cookware for induction.
The saucepans make noise during cooking. Your hob makes a clicking sound during cooking.	This is normal with some types of cookware. This is caused by the transfer of energy from the hob to the cookware.	Nothing. There is no risk, neither to your hob nor to your cookware.
The fan continues to function a few minutes after your hob is turned off.	Cooling of the electronic components. Working normally.	Nothing.

**Warning**

In the event that there is a break, crack or opening—even minor—in the vitroc ceramic glass, immediately disconnect your appliance to avoid the risk of electric shock. Contact the After-Sales Service Department.

6 / COOKING CHART

• COOKING CHART

		FRY BRING TO A BOIL		COOK/BROWN RETURN TO BOILING BOILING LIGHT BROTHS		COOK/SIMMER			KEEP WARM	
		9	8	7	6	5	4	3	2	1
SOUPS	BROTHS						●			
	THICK SOUPS								●	
FISH	COURT BOUILLON				●					
	FROZEN FOODS					●				
SAUCE	THICK, FLOUR-BASED						●			
	BUTTER-BASED WITH EGGS (BEARNAISE, HOLLANDAISE) PREPARED SAUCES						●			●
		9	8	7	6	5	4	3	2	1
VEGETABLES	ENDIVES, SPINACH								●	
	DRIED BEANS								●	
	BOILED POTATOES					●				
	GOLDEN BROWN POTATOES					●				
	SAUTEED POTATOES					●				
	DEFROSTING VEGETABLES								●	
MEAT	MEAT, NOT TOO THICK			●						
	STEAKS, IN SKILLET				●					
	GRILLED MEATS (CAST IRON GRILL)			●						
FRYING	FROZEN FRENCH FRIES	●								
	FRESH FRENCH FRIES	●								
		9	8	7	6	5	4	3	2	1
MISCELLA-NEOUS	PRESSURE COOKER (ONCE IT STARTS WHISTLING)						●			
	COMPOTES					●				
	CRÊPES				●					
	CRÈME ANGLAISE			●						
	MELTED CHOCOLATE									●
	JAMS					●				
	MILK			●						
	EGGS, FRIED				●					
	PASTA				●					
	JARS OF BABY FOOD (DOUBLE BOILER)					●				
	MEAT STEW			●						
	SPANISH RICE								●	
	RICE PUDDING								●	

WARRANTY AND SERVICE

DOMESTIC WARRANTY - FULL FIVE YEAR WARRANTY

In addition to all statutory rights which you, the Consumer, have under the relevant laws in respect of this appliance, during the first five years of ownership as the original purchaser of this Kleenmaid appliance, we guarantee that any fault caused by faulty material or workmanship becoming apparent will be rectified free of charge for parts and labour, provided that all service is performed during normal working hours by Kleenmaid or their designated Agents. Where the appliance is installed outside the normal servicing area of the above, the Purchaser must pay for the cost of transporting the appliance to and from the Agent or the Agent's travelling cost to and from the Purchaser's home.

COMMERCIAL WARRANTY - ONE YEAR WARRANTY

When this appliance is installed in a commercial application, you, the Consumer, have under the relevant laws in respect of this appliance, during your first one year of ownership as the original purchaser of this Kleenmaid appliance, we guarantee that any fault caused by faulty material or workmanship becoming apparent, will be rectified free of charge for parts and labour, provided that all service is performed during normal working hours by Kleenmaid or their designated Agents. Where the appliance is installed outside the normal servicing area of the above, the Purchaser must pay for the cost of transporting the appliance to and from the Agent or the Agent's travelling cost to and from the Purchaser's home.

WHAT THESE WARRANTIES DO NOT COVER

We are not responsible for any damage or malfunction unless caused by a defect in material or workmanship. This includes but is not limited to abuse, misuse, improper installation and transportation damage. We are not responsible for any consequential damages from any malfunction. The Consumer must make the appliance available for servicing and shall bear any costs incurred for any de-installation and/or re-installation required to make the appliance available for servicing. Kleenmaid is not liable for any consequential damage incurred during de-installation or reinstallation.

WARRANTY DOES NOT COVER REPLACEMENT OF LIGHT GLOBES OR GLASS BREAKAGE DUE TO IMPACT

In case of fractured glass do not use your appliance.

WARRANTY REGISTRATION / SERVICE ASSISTANCE

Please complete warranty details below and retain together with your proof of purchase document

These documents will need to be viewed by our Service Representative should you request in warranty service.

To assist you when phoning our After Sales Service number to arrange a service call please complete the following details and have them ready when you call.

Model Number _____ Date of purchase _____

Kleenmaid Store purchased from _____ Date of installation _____

KLEENMAID AFTER SALES SERVICE
1300 652 100
WARRANTY AND SERVICE

**Other products available in the Kleenmaid
Range of appliances**

Washers

Dryers

Dishwashers

Ovens

Cooktops

Outdoor Cooking Centres

Built In Espresso Coffee Machines

Rangehoods

Freestanding Ranges

Sinks

Waste Disposals

Taps

Cookware

Refrigerators

Freezers

Wine Cellars

Vacuum Cleaners

**For sales information on the full range of quality appliances
Phone 13 13 08**