

COOKTOP

c o l l e c t i o n

Instructions for Use and Warranty Details

Ceramic Cooktop

CH16 - Ceramic 600 mm





Congratulations on the purchase of your new Kleenmaid appliance. This appliance has been designed and manufactured to give you years of reliable performance. For best results, carefully read the instructions on how to install your new appliance. Correct installation will avoid delays and unnecessary service calls.

Once installation is complete, read this booklet and get to know the controls and the features of your new appliance.

**If you need further information call our
Customer Care Centre
1300 652 100**

We reserve the right to alter the specifications with no influence on the operation of the appliance. This instruction manual cannot be reason for claim.

CONTENTS

General description	2
Using the controls	2
Using pans.....	3
Cleaning	4
Installation	5,6
Wiring diagram	7
Warranty and service.....	9

WARNINGS

- Repair of any fault in your hob must be carried out only by an Authorized Repair Agent, otherwise the guarantee is not valid.
- The technical details and identification of the appliance are shown on the specification plate.

Consult this plate before proceeding with electrical connection.

- Electrical connection must be carried out by a specialist familiar with the laws and official regulations governing such installation in your State.

GENERAL DESCRIPTION

Model CH16

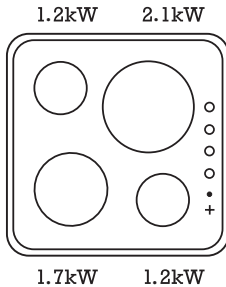

CONTROL SETTING	1	2	3	4	5	6	REMARKS
TYPE OF HOTPLATE							
LARGE HOTPLATE (2.1 kW)	220 W	350 W	550 W	950 W	1.500 W	2.100 W	DIFFERENT ELEMENTS COME INTO PLAY DEPENDING ON SETTING
MEDIUM HOTPLATE (1.7 kW)	180 W	280 W	450 W	750 W	1.200 W	1.700 W	
SMALL HOTPLATE (1.2 kW)	130 W	200 W	325 W	500 W	825 W	1.200 W	

USING THE CONTROLS

- 1** Make sure that you turn on the right controls for the burner you wish to use.

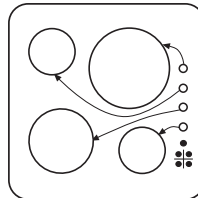

- 2** Turn the selector knob to the desired setting: Setting 1: MINIMUM.
The ON light will come on.

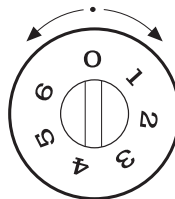

- 3** As soon as a hotplate gets warm, the corresponding residual heat warning light will come on. After switching off, the light will remain on until the hotplate cools (approximately 30 minutes).

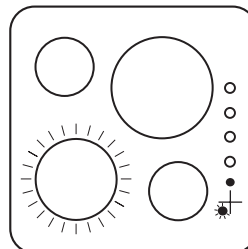

USING PANS

Most stainless steel, enamel, iron, ceramic and copper pans can be used on vitroceramic hobs.

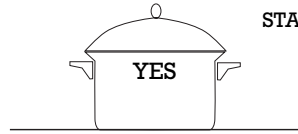

STAINLESS STEEL
ENAMEL
CERAMIC
COPPER

Aluminium pans are not recommended as they may stain the vitreous surface, unless they have stainless-steel covered bottoms.
(Consult manufacturer of the aluminium cookware before using on the ceramic cooktop)

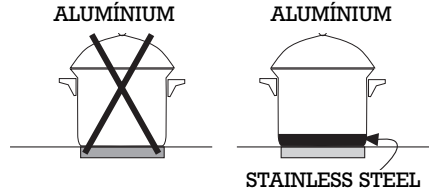

Hotplates should not be switched on without a pan on top. The base of the pan should be flat and dry. Pans that have been used on gas cookers are not normally flat and absorb heat poorly.

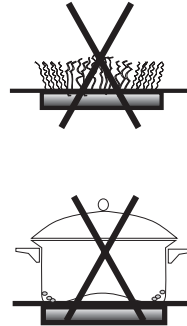

Make sure that the diameter of the pan is at least that of the hotplate.

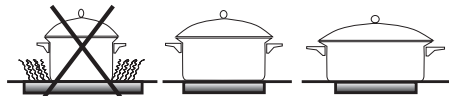

Avoid scraping pans over the vitroceramic surface, as it may become scratched. Always lift the pan.

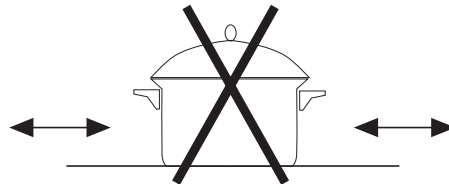

Never use tinfoil or plastic containers. They will melt and fuse permanently with the vitroceramic surface.

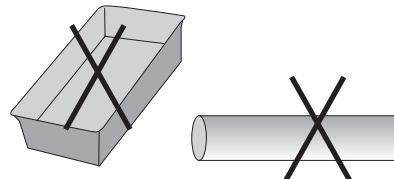

CLEANING

IMPORTANT: If the vitroceramic surface breaks or you notice cracks in it, disconnect the equipment. Call Kleenmaid Customer Call Centre for service assistance.

Clean the vitroceramic surface frequently, when it is cool. Never use abrasive products or pads. Clean with a damp cloth and soapy water.

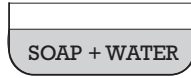

Once a week, clean thoroughly with specific products that preserve and protect vitroceramic hobs. Scrape off hard stuck dirt with the scraper (Included in accessory bag).

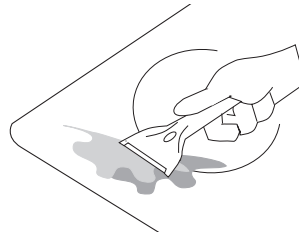

If sugar (or sugary matter) or plastic is accidentally burnt on the hob, remove at once with the scraper while still hot. Otherwise the spill may leave a permanent mark.

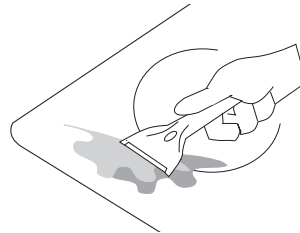

IMMEDIATELY

Do not use the hob as a work surface. Be particularly careful with dirt like soil or dust from vegetables, cleaning powders, etc. which may scratch the surface when pans are placed over it.

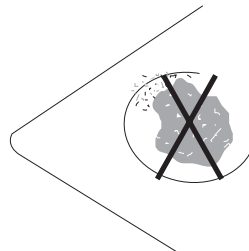

INSTALLATION

- 1** Cut out a piece of the worktop following the dimensions provided below.
Minimum distance between hole and sidewall 100 mm.
Minimum distance between hole and rearwall 50 mm.

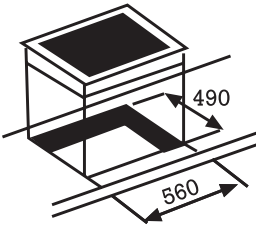
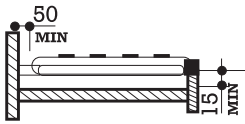
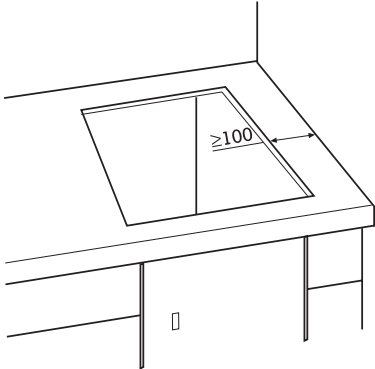

- 2** Place the hob face down on a table. Remove the backing paper and affix the sealing gasket all round the perimeter.

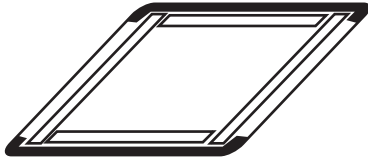
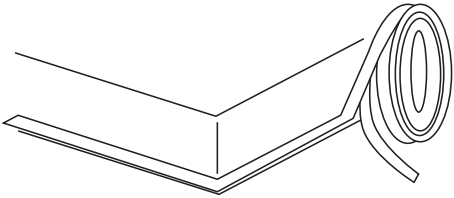

INSTALLATION

- 3** Place the hob alongside the cavity in the worktop and connect the power cable to the electrical socket.

IMPORTANT: Carry out connection with the power disconnected. There must be a good grounding connection. Kleenmaid will not accept responsibility for installations carried out other than as directed here.

The cooktop is equipped with a power input cable for high temperatures and must be installed with this cable.

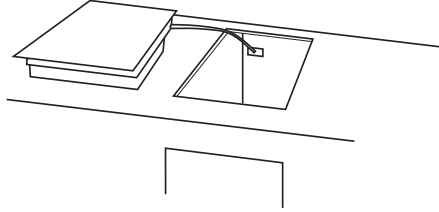

- 4** Next insert the hob in the worktop cavity, pressing down firmly to ensure a good seal.

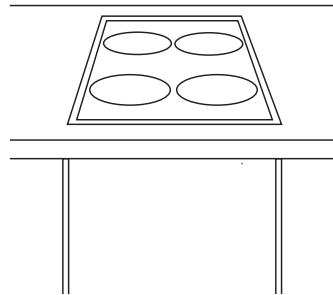

- 5** Fix the 4 clamps underneath the hob to the 4 corners of the cavity.

(Clamps, brackets and nuts are supplied in accessory bag).

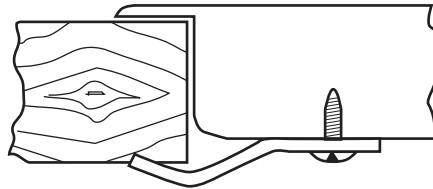

NOTE: This equipment complies with EMC Standards.

WIRING DIAGRAM

TIPO: VM - MPGP

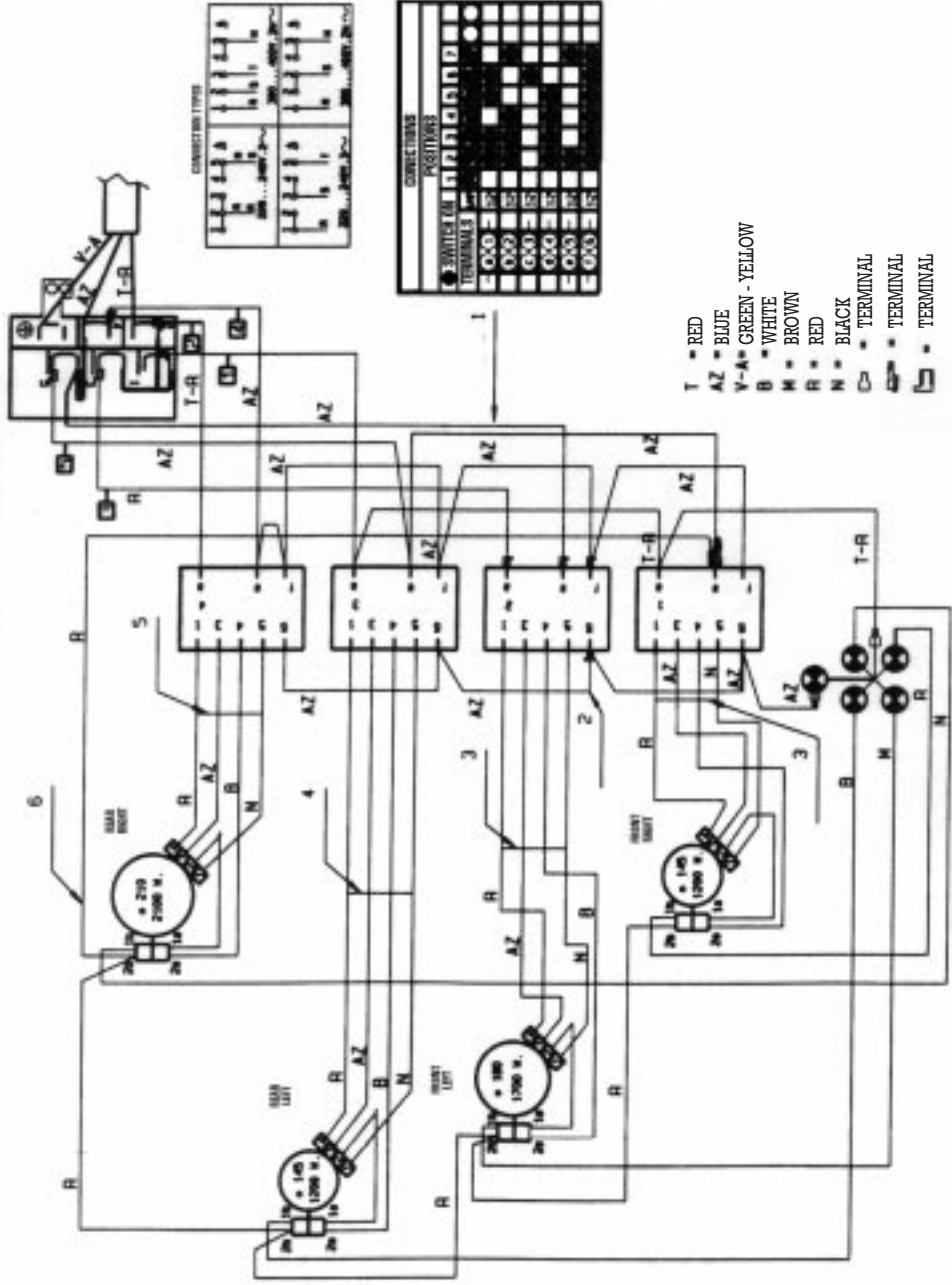

CONNECTION TABLE

1	2	3	4	5	6	7	8	9	10	11	12
1	2	3	4	5	6	7	8	9	10	11	12

CONNECTIONS POSITIVE

1	2	3	4	5	6	7	8	9	10	11	12
1	2	3	4	5	6	7	8	9	10	11	12

- T = RED
- AZ = BLUE
- V-A = GREEN - YELLOW
- B = WHITE
- M = BROWN
- R = RED
- N = BLACK
- ⊖ = TERMINAL
- ⊕ = TERMINAL
- ⊘ = TERMINAL

WARRANTY AND SERVICE

DOMESTIC WARRANTY - FULL FIVE YEAR WARRANTY

In addition to all statutory rights which you, the Consumer, have under the relevant laws in respect of this appliance, during the first five years of ownership as the original purchaser of this Kleenmaid appliance, we guarantee that any fault caused by faulty material or workmanship becoming apparent will be rectified free of charge for parts and labour, provided that all service is performed during normal working hours by Kleenmaid or their designated Agents. Where the appliance is installed outside the normal servicing area of the above, the Purchaser must pay for the cost of transporting the appliance to and from the Agent or the Agent's travelling cost to and from the Purchaser's home.

COMMERCIAL WARRANTY - ONE YEAR WARRANTY

When this appliance is installed in a commercial application, you, the Consumer, have under the relevant laws in respect of this appliance, during your first one year of ownership as the original purchaser of the Kleenmaid appliance, we guarantee that any fault caused by faulty material or workmanship becoming apparent, will be rectified free of charge for parts and labour, provided that all service is performed during normal working hours by Kleenmaid or their designated Agents. Where the appliance is installed outside the normal servicing area of the above, the Purchaser must pay for the cost of transporting the appliance to and from the Agent or the Agent's travelling cost to and from the Purchaser's home.

WHAT THESE WARRANTIES DO NOT COVER

We are not responsible for any damage or malfunction unless caused by a defect in material or workmanship. This includes but is not limited to abuse, misuse, improper installation and transportation damage. We are not responsible for any consequential damages from any malfunction.

WARRANTY DOES NOT COVER REPLACEMENT OF LIGHT GLOBES OR GLASS BREAKAGE DUE TO IMPACT

In case of fractured glass do not use your appliance.

WARRANTY REGISTRATION

Please complete the enclosed warranty card and post it to us or phone our Customer Call Centre.

SERVICE ASSISTANCE

To assist you when phoning our Customer Call Centre number to arrange a service call please complete the following details and have them ready when you call.

Model Number: _____ Date of purchase: _____

Kleenmaid Store purchased from: _____ Date of installation: _____

KLEENMAID CUSTOMER CALL CENTRE

CONTACT NUMBER

1300 652 100

Other products in Kleenmaid's
range of world's best appliances:

- Washers
- Dryers
- Vacuum Cleaners
 - Dishwashers
 - Cooktops
 - Cookware
 - Rangehoods
 - Ovens
- Refrigerators & Freezers
 - Sinks & Taps
- Waste Disposals

**For sales information on the full range of quality
kitchen and laundry appliances, phone 13 13 08**

Kleenmaid Head Office:

PO Box 5560, Maroochydore Business Centre, Queensland 4558



Printed on recycled paper.