

***Brandt***

220/240V - 50/60Hz 5600W REF CONSTRUCTEUR 214

Type **IB 61**

INDUCTION

**IB 61**

***Brandt***

---

	USES	
1/2	<b>VERY LOW</b>	melting butter, chocolate, keeping warm sauces, custards...
3	<b>SLOW</b>	rice pudding reheating
4/5	<b>SIMMER</b>	purée, pulses, soups, jam, compotes
6	<b>MEDIUM</b>	pasta, boiled rice, boiling milk
7/8	<b>HIGH</b>	steaks, fast frying, pancakes
9	<b>VERY HIGH</b>	deep frying, fast boiling

## For the user      **How induction works**

- Congratulations on choosing an induction hob, a system which is revolutionising cooking.

With your hob, because the heat required to cook the food is produced directly in the interior of the pan, **the ceramic top barely becomes hot** for it receives **ONLY** the heat from the pan placed on it.

Compared to a standard hob your induction hob is:

- **MORE ECONOMICAL:** when a pan is removed the heating zone switches off instantly.
- **FASTER:** output of 2800 W available instantly on the heating zone
- **MORE PRECISE:** the hob reacts instantly to the controls
- **SAFER:** the temperature of the ceramic top remains low

- Operating principle:

The “induction” currents instantly heat the pan\* which transfers its heat to the food it contains.

\*Enamelled steel, cast iron or stainless steel pans are suitable for induction cooking.

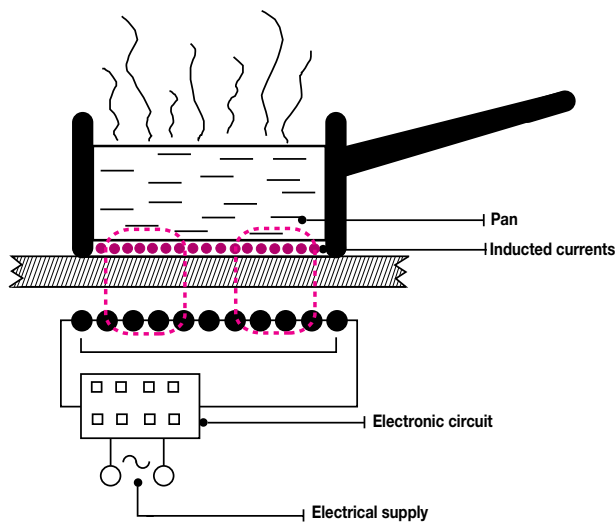

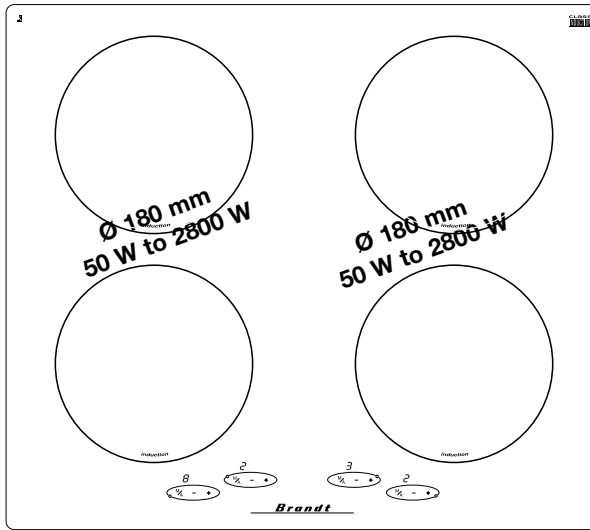

Display showing (1 to 9) the power level set for each heating zone.



Symbol indicating the heating zone on the hob  
Example shown: front left zone



Power level adjustment + or - for each heating zone.



On / off touch control for each heating zone

## ■ Turning on a heating zone

---

Locate the touch controls on the keypad which corresponds to the cooking zone on which you have placed your pan.

- Press the  $\frac{M}{A}$  touch control.

The power level display shows 0, the hob is switched on.

- Set the power level required by pressing the  $+$  touch control.

Once you have pressed the  $\frac{M}{A}$  touch control, if you do not select a power level, the instruction will be cancelled automatically after 10 seconds.

- Adjust the power level during cooking

You can adjust the power level from 1 to 9 at any time during cooking using the  $+$  or  $-$  touch controls.

## ■ Turning off a heating zone

---

- Press the  $\frac{M}{A}$  touch control of the zone concerned.

## ■ Using 2 cooking zones simultaneously

---

These two zones have a **total of 2800 W of power** available, **distributed automatically** between the front and rear zones.

This means that when one zone is being used at maximum, the power of the other is automatically reduced.

***The most recent instruction always takes priority.***

Check regularly that there are no objects (tea towel, paper, etc.) which might block the air inlet located below your hob (see fitting P. 12).

- **“Electronic” safety feature**

A sensor constantly monitors the temperature of the electronic circuits. If the temperature rises too high the power supplied by the hob will be reduced.

- **“Empty pan” safety feature**

Each heating zone is fitted with a sensor which constantly monitors its surface temperature, so no more danger of overheating caused by empty pans.

- **Detection of an object or a pan on a heating zone**

A small object such as a fork, a spoon or even a ring left on the hob is not detected as a saucepan.

The display flashes and no heating power is produced.

The safety system acts in the same way when it detects a pan which is not suitable for cooking by induction.

**IMPORTANT:** If an oven is located under your hob (see installation options) the thermal safety devices on the hob will prevent its simultaneous use when the oven is in pyrolysis mode.

*For the attention of wearers of pacemakers  
and active implants:*

The functioning of the hob is in conformity with current standards on electro-magnetic interference.

Your induction hob also fully complies with the legal requirements (EC directives 89/336/EEC). It has been designed not to interfere with the operation of other electrical appliances as long as these comply with the same legislation.

*Your induction hob generates magnetic fields in its immediate area.*

So that there is no interference between your hob and a pacemaker, the latter must be designed in conformity with the relevant regulations.

In this respect, we can only guarantee the conformity of our own product.

Insofar as the conformity of the pacemaker or any incompatibility is concerned, you should consult its manufacturer or your doctor.

## ■ Precautions for use

---

- The ceramic surface is very strong, however, it is not unbreakable: do not drop pans onto it.
- Saucepans with damaged bases may trap and transfer materials which could cause staining or scratching of the hob.
- Do not drag saucepans across the hob surface as in the long term this will damage the design on the ceramic top.

**These faults, which do not prevent operation or use of the hob, are not covered by the guarantee.**

**The hob must not be used as a storage area.**

- Do not store **CLEANING** products or any products which might be **INFLAMMABLE** in the unit located under your hob.
- When plugging electrical appliances into a socket nearby, make sure that the power cable does not come into contact with the heating zones.

**If a crack appears in the ceramic top,  
disconnect the appliance from  
the power supply immediately by removing  
the fuses or activating the circuit breaker.  
*Do not use any part of the hob until the ceramic top has been  
replaced***

## ■ Advice on cooking

- Do not leave an empty pan on a heating zone.
- The pan should be centred on the heating zone.
- Never heat up an unopened tin, it may explode; this advice applies to all cooking systems.
- When you use a pan with a non-stick lining (Teflon type) to cook with no fat or very little, preheat it at setting **6** for a moment.
- You are advised not to place metal cooking utensils, cutlery, knives and similar metal objects on the hob. They may become hot if they are near a functioning cooking zone.
- Using a pan which is smaller than the size of the cooking zone indicated on the ceramic top is quite acceptable and does not result in a loss of energy, unlike other, standard hobs (electricity, gas).

**When cooking, never use aluminium foil  
and never place products wrapped  
in aluminium foil directly on the induction hob.  
The aluminium will melt and damage your appliance irreparably.**

# Choice of pans

## ■ Which types of pan are most suitable?

You probably already have some suitable pans.

- PANS MADE OF ENAMELLED STEEL WITH OR WITHOUT NON-STICK COATING.

casserole, deep fryer, frying pan, grill pan, etc.

- CAST IRON PANS

To prevent the ceramic top on your hob from being scratched choose a pan with an enamelled base, otherwise never slide the pan across the surface of the hob.

- STAINLESS STEEL PANS DESIGNED FOR INDUCTION COOKING

Most stainless steel pans are suitable for induction cooking (casseroles, sauce-pans, frying pan, deep fryer, etc.).

- ALUMINIUM PANS WITH SPECIAL BASE

Choose pans with a heavy base, which will ensure more even cooking results (the heat is better distributed).

- NB. Pans which do not have a completely flat base may be suitable, however, they must not be too misshapen.

This hob carries the “CLASS INDUCTION” symbol .

By choosing a pan bearing the same symbol, you will be assured of its complete compatibility with your hob, under normal conditions of use.

To help you in your choice, a list of utensils is supplied with this instruction book.

## ■ Which materials are incompatible?

*PANS MADE OF GLASS, CERAMIC OR EARTHENWARE, OR OF ALUMINIUM WITHOUT A SPECIAL BASE OR OF COPPER, OR OF CERTAIN TYPES OF NON-MAGNETIC STAINLESS STEEL.*

## ■ The “pan” test

Its advanced technology enables your induction hob to recognise most types of pan.

Place your pan on a heating zone at power setting 3:

- if **the display does not flash** your pan is **compatible**,
- if it **flashes** then your pan **cannot be used** for induction cooking.

TYPE OF STAIN	WHAT TO DO	ACCESSORIES REQUIRED
Minor	Soak the area to be cleaned thoroughly with hot water, then wipe clean	cleaning sponges
Accumulated burnt-on stains	<b>Soak</b> the area to be cleaned thoroughly with <b>hot water</b> , if necessary, finish off with the rough side of a scouring sponge, then <b>wipe clean</b> .	cleaning sponges
Rings and traces of limescale	<ul style="list-style-type: none"> <li>• Apply <b>hot white spirit vinegar</b> to the stain, leave to act then <b>wipe off</b> with a soft cloth.</li> <li>• Or use a <b>commercial cleaner</b>.</li> </ul>	Special ceramic hob cleaning paste
Burnt-on stains following sugar spillage, melted aluminium or plastic.	<ul style="list-style-type: none"> <li>• Use a <b>special ceramic hob scraper</b> to loosen the residue</li> <li>• Or apply a <b>special ceramic hob cleaner</b> to the surface, preferably one which contains silicone (protective action).</li> </ul>	Special ceramic hob cleaner

For the user

# You are worried that your hob is not functioning properly...

... this does not necessarily mean there is a fault.

**Always check the following points first.**

YOU NOTICE THAT...	POSSIBLE CAUSES	WHAT TO DO
<i>The fan continues operating for a few minutes after your hob is switched off.</i>	<i>The electronic system is being cooled.</i>	<i>This is quite normal</i>
<i>The top of your hob is always slightly warm (even when off)</i>	<i>The electronic system is on standby, as with any other electronic appliance (TV, transformer).</i>	<i>This is quite normal</i>
<i>Your hob makes a slight clicking noise.</i>	<i>This is caused by the distribution of power between two induction cooking zones.</i>	See <b>"how induction works"</b>
<b>When you switch the appliance on, your mains cuts out.</b>	<i>Your hob has been wrongly connected.</i>	<i>Check the connections and the mains connection are correct.</i>
<b>When you switch it on, only one side of your hob functions.</b>	<i>Your hob has been wrongly connected.</i>	<i>Check the connections and the mains connection are correct.</i>
<b>When you switch the appliance on a display lights</b>	<i>Normal operation</i>	<b>NOTHING:</b> see section <b>with notes on connection</b>
<b>The hob does not work. The lights on the keypad stay off.</b>	<i>The appliance has no power. Either the power supply or the connection is faulty.</i>	<i>Inspect the fuses and the circuit breaker.</i>
<b>The hob does not work, the display indicates an intermittent «Point».</b>	<i>Your hob has been wrongly connected.</i>	<i>Check the connections. The supply voltage is too high.</i>
<i>The display indicates the message <b>F7</b></i>	<i>The electronic circuits have overheated.</i>	See section <b>building in.</b>
<b>The hob does not work, the display indicates another message.</b>	<i>The electronic circuit is dysfunctioning</i>	<i>Call your After Sales Service.</i>
<i>After having switched on a heating zone, the lights on the keypad continue to flash.</i>	<i>The pan you are using is unsuitable for cooking by induction or has a diameter less than 12 cm.</i>	See section <b>choice of pans.</b>

**Please comply scrupulously with the following points:**

- The walls above the worktop and immediately next to the hob must be heat-resistant.
- Laminated surfaces and the adhesives used to fix them must be heat-resistant to avoid any deterioration.
- The cool air gap located underneath and to the rear of the hob is there to increase its reliability by ensuring that it remains cool in all types of fitting arrangement.
- The hob must not be installed above a dishwasher, washing machine, refrigerator or freezer.

**● Protecting the cut-out:**

The chipboard used in the manufacture of worktops swells relatively quickly when in contact with humidity. Apply a varnish or a specialist glue to the edge of the cut-out to protect it from any steam or condensation which may originate from under the worktop.

- Make a cut-out in the worktop with the dimensions required. The minimum distance of 40 mm should be measured from the wall and any side walls (rear and/or sides).

Protection from heating is Type Y in accordance with IEC 335-2-6

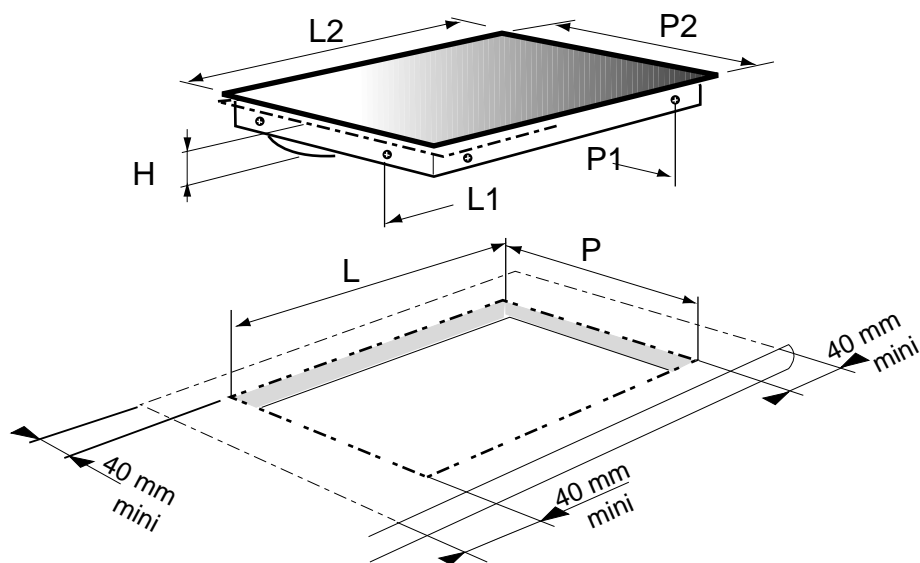

### Technical data

Operating voltage	220/240V - 50/60Hz
Total power consumption	5600W

#### Cut-out dimensions of the furniture

Width	<b>L</b>	560 mm
Depth	<b>P</b>	490 mm
Space needed under the worktop	<b>H</b>	63,3 mm

#### Overall dimensions below the worktop

Width	<b>L1</b>	555 mm
Depth	<b>P1</b>	488 mm

#### Overall dimensions above the worktop

Width	<b>L2</b>	580 mm
Depth	<b>P2</b>	510 mm

<b>Weight</b>	approx. 14.5 kg
<b>Manufacturer</b>	N°214

## ■ Installation options

- above an empty unit or drawer
- above an oven of another brand
- above an oven of the same brand

Your induction hob must always be well-ventilated.

Make sure that the flow of air through the ventilation grille at the back is completely unobstructed.

### Above an empty unit or drawer

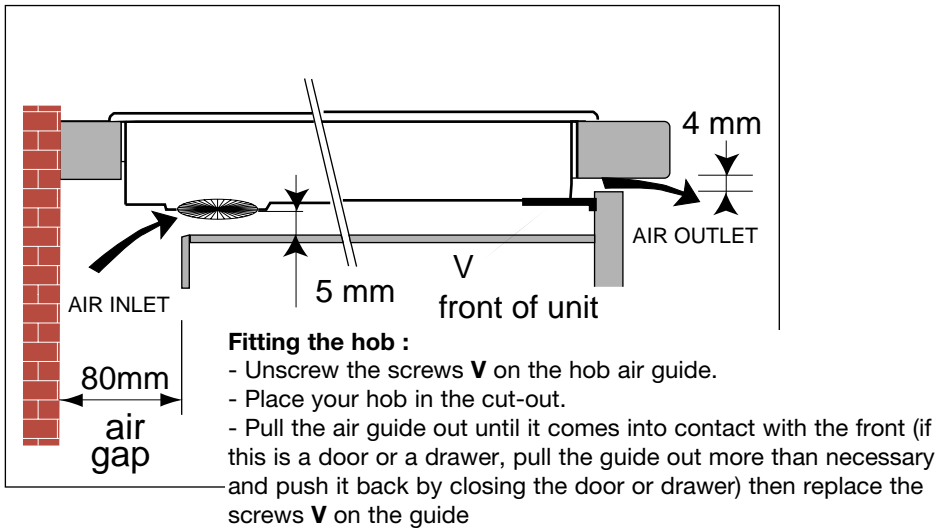

### Above an oven of another brand

It is essential that you install an insulation kit between the oven and the hob (available from your dealer's After Sales Service). This arrangement **restricts** installation of the oven to the **lower position** in the unit.

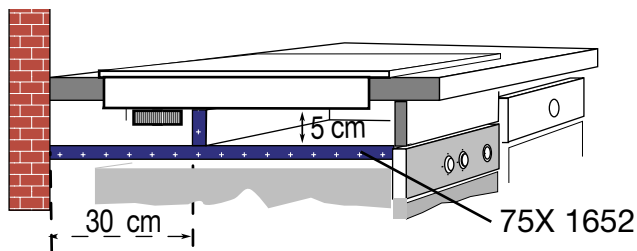

# Building in

## Above an oven of the same brand

Your oven carries the **BRANDT** label, and it has an upper ventilation system and the hob can therefore be fitted directly into the worktop above the oven in the higher position.

- It is essential that **an air inlet of 30 cm<sup>2</sup>** be made in the left or right wall of the oven housing unit.

**Reminder:** the hob's thermal safety devices prevent its simultaneous use with an oven in pyrolysis mode.

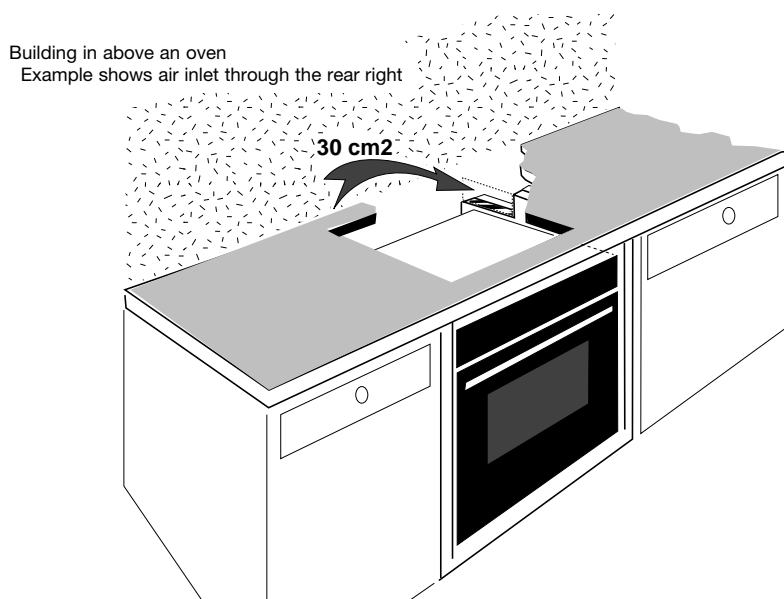

## ■ Electrical Connection

These hobs are supplied with an 05 VVF power supply cable (cross-section 1.5 mm<sup>2</sup>), with 5 cores (of which one for the earth: yellow/green) and should be connected to the mains by a socket which complies with the EEC 7 regulations or by using a double-pole circuit breaker with a contact gap of at least 3 mm.

If this power supply cable is damaged, or if you wish to change it, it can only be replaced by your After Sales Service as this requires specialist tools.

### - 220/240 V single phase

Connect the three wires to your mains supply, in accordance to the colour of the wires.

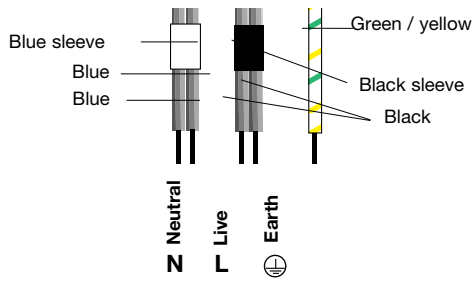

### - 400 V 2N three phase

Connect the four wires to your mains supply, in accordance with the colour of the wires.

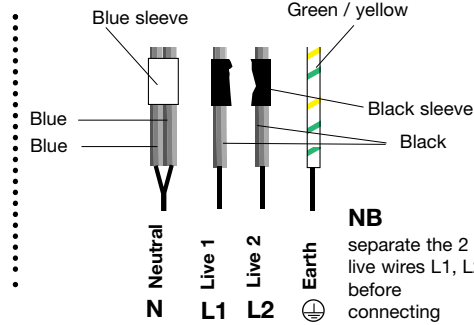

Your mains fuse must be: 32 amp

### Remarks

When your hob is first connected to the power supply or after a long power cut, a code lights up on the keypad.

It disappears automatically after about 30 seconds or the first time any of the touch controls on the keypad is pressed. This display is normal and reserved for the use, as required, of your After Sales Service.

When connecting to a 400 V ~ three phase mains supply, if your hob malfunctions, check that the neutral wire has been connected properly. These precautions will also protect your other electronic appliances.