

COOKING  
c o l l e c t i o n

Instructions for Use  
and Warranty Details

SOE102X - Built in Stainless Steel Steam Oven







**C**ongratulations on the purchase of your new appliance. This appliance has been designed and manufactured to give you years of reliable performance.

For best results, carefully read the instructions on how to install your new appliance. Correct installation will avoid delays and unnecessary service calls.

Once installation is complete, read this booklet carefully and get to know the controls and the features of your new appliance.

We reserve the right to alter the specifications of the appliance. This instruction manual cannot be a reason for a claim.

## Table of Contents

<b>Introduction</b>	<b>p. 5</b>
<b>Steam cooking</b>	
Overview	<b>p. 6</b>
<b>What does your oven look like?</b>	<b>p. 7</b>
<b>Accessories</b>	<b>p. 8</b>
<b>How do you install your oven?</b>	
Electrical connection	<b>p. 9-10</b>
Build-in	<b>p. 11</b>
<b>How do you program for immediate cooking?</b>	<b>p. 12-13</b>
Locking display	<b>p. 14</b>
Water management	<b>p. 14</b>
<b>Cooking chart</b>	<b>p. 15-16</b>
<b>Steam cooking</b>	<b>p. 17-18</b>
<b>How do you care for your oven?</b>	<b>p. 19</b>
<b>Cleaning the oven cavity</b>	<b>p. 20-21</b>
<b>Changing the bulbs</b>	<b>p. 22</b>
<b>What to do in case of malfunctions?</b>	<b>p. 23</b>
<b>How to contact us?</b>	<b>p. 23</b>
<b>Warranty and service</b>	<b>p. 24</b>

## Introduction

Dear Customer,

Thank you for buying a **KLEENMAID oven**.

Our design staff have produced a new generation of kitchen equipment, to help you to give free rein to your culinary talents and to enjoy great food every day.

You will find that the clean lines and modern look of your **KLEENMAID oven** blends in perfectly with your kitchen décor. It is easy to use and performs to a high standard.

The **KLEENMAID** product range also includes a huge choice of cookers, hobs, extractor hoods, dishwashers, microwave ovens and refrigerators ready to be built in and coordinated with your new **KLEENMAID oven**.

Of course, we make every effort to ensure that our products meet all your requirements, and our Customer Relations department is at your disposal, to answer all your questions and to listen to all your suggestions (see back cover of manual).

A specialist in the world of cooking equipment, **KLEENMAID** contributes to your culinary success, shared pleasures and hospitality, bringing you products that are ever more efficient, easy to use, environmentally friendly, attractive and reliable.

The **KLEENMAID** name.

Throughout this manual,



indicates safety recommendations,



indicates advice to help you make the best use of your oven

# Steam cooking

## Overview

Steam cooking presents nothing but advantages if you follow the instructions for use. Healthy and natural, steam cooking preserves the full flavour of foods. A delicate sauce or aromatic herb seasonings add that something extra that makes the difference.

This kind of cooking releases no odours. There is no need to season the cooking water with herbs or spices; however, you can flavour fish by placing it on a bed of seaweed or make a savoury poultry dish by adding a bunch of rosemary or tarragon.

You can simultaneously cook meat, fish and vegetables.

Steam cooking gently reheats pasta, rice and mashed potatoes with no risk of food sticking or drying out.

It makes it easier to cook puddings, flans, rice pudding, etc. covered with aluminium foil, the condensation water does not add moisture to the preparations.

There is no need to season before cooking--not even the steam water.

To make meat look more appetising, quickly brown it on all sides with hot butter in a pan.

Compared to boiling, steam offers nothing but advantages:

It is quick: cooking starts immediately, whereas for food in a water-filled dish, the cook time only begins counting down once the water returns to a full boil.

It is healthy: vitamins (those that are water soluble) and minerals are well preserved because they scarcely dissolve in the condensation water that touches the food.

Moreover, no fats are used for this type of cooking.

The steam maintains the taste of food. It does not add odours, nor the taste of the grill or the pan. Furthermore, it takes nothing away because the food is not diluted in the water.

Words of advice: there is no point in using this cooking method to prepare fish that is not fresh or vegetables left in the refrigerator for a week--the results are catastrophic!

The steam does not transfer flavours or aromas; therefore do not hesitate to save both time and money by cooking items side by side, but without touching. For example, you can cook fish next to a dessert.

Steam is also appropriate for blanching, defrosting and reheating or even holding warm, especially sauces.

First use a very small amount of fat to heat meats like poultry, veal and pork so that they take on an appetizing browned appearance. Then finish cooking them using the steam method.

Cut into pieces, food cooks faster and more evenly than if left whole.

## What does your oven look like?

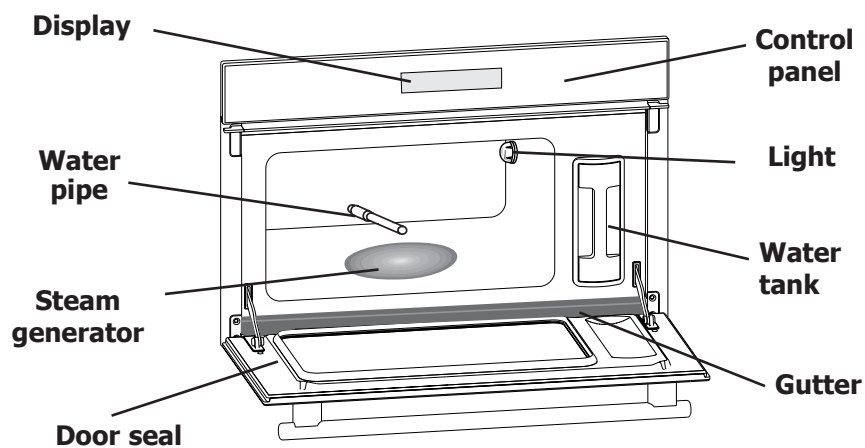

### Close-up of control panel

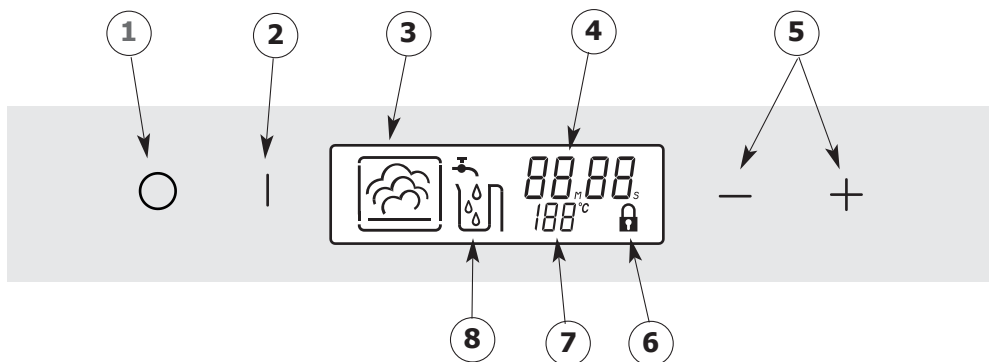

1. Off button
2. Start button
3. Steam cook symbol
4. Cook time display
5. + and - touch controls for time adjustment
6. Touch pad-locking mechanism
7. Temperature indicator
8. Water circuit problem indicator

## Accessories

### Cookware

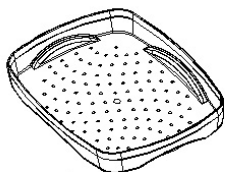

Pierced cooking dish to prevent contact between food and the condensation water.

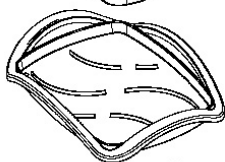

Drip tray that makes it possible to recover the condensation water.



Stainless steel removable support grid: it must be placed in the oven.



**The cookware may be cleaned in the dishwasher.**

(Optional Accessory)

SOK - Steam oven double dish kit which includes the following:

- 1 x high level support grid
- 1 x pierced cooking dish
- 1 x drip tray

### Removable water tank

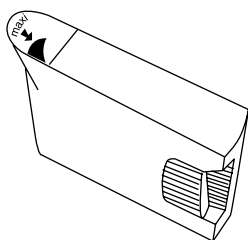

The water tank that allows for independent water supply to the oven. Its capacity is approximately one litre (maximum level).



Using water with a low level of lime will make it easier to care for your oven.



Using demineralised water is forbidden (not for human consumption).

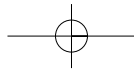

## How do you install your oven?

### **Electrical connection**

For permanent installation, be mindful to add a standardised, compliant cut-off device in the electrical conduit. Otherwise the appliance must be positioned so that the electrical outlet is accessible after the unit has been built-in. You must use an electrical receptacle that contains a ground wire and is connected in compliance with applicable safety standards. Your electrical installation must be equipped with 10-ampere thermal-sensitive protection. Do not operate the oven if the power cable or its plug are damaged. In this case, they must be replaced by the manufacturer, its After Sales Service department or a person of similar qualifications so as to avoid any danger.

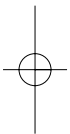

### **Before using the appliance for the first time**

Remove all objects from the oven cavity and, if necessary, any stickers and protective sheets placed on the appliance.



Operating voltage .....	220-240 V ~ 50 Hz
Total oven power .....	1.77 kW
<b>Energy consumption</b>	
- heating up to and holding at 100°C for one hour .....	0.71 kWh
<b>Internal dimensions of your oven</b>	
Width .....	38.5 cm
Height .....	18.2 cm
Depth .....	33.5 cm
<b>Net capacity</b> .....	23.5 litres

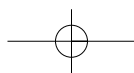

**Do not remove  
the identification  
plate!**

Clean and dry the control panel, the drip pan, the shelf and the steam generator using a mild detergent.

**Safety  
during use**

The steam oven should be turned on for 10 minutes before its first use. Ensure that the ventilation around the appliance is adequate. If necessary use a rangehood. The steam generator can **lead to burns**. When removing cooked and hot food, you should use a dishcloth and wet heat resistant gloves. Do not apply excess weight to the open door. Do not sit or climb on it. It is possible to use ceramic, porcelain or heat resistant plastic crockery. Never use paper or cardboard plates or dishes as these will not withstand humidity. Apart from the accessories supplied, you should use only suitable heat resistant cooking dishes. Be sure to observe the manufacturer's recommendations. Do not use the pierced cooking dish for rice, terrines or pasta dishes. For these dishes use a non perforated recipient. After use, check that the appliance is turned off properly. The appliance is not intended for use by children or infirm persons without supervision. Young children must be supervised to ensure that they do not play with appliance.

## **Build-in**

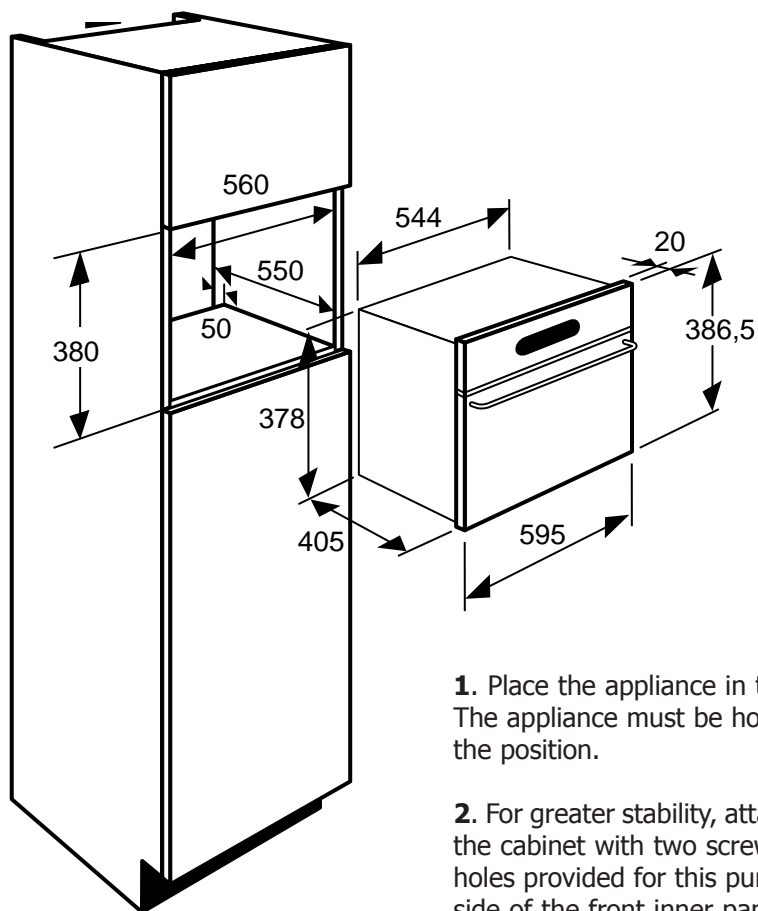

- 1.** Place the appliance in the nook.  
The appliance must be horizontal. Check the position.
- 2.** For greater stability, attach the oven in the cabinet with two screws through the holes provided for this purpose on either side of the front inner panels.
- 3.** Make the electrical connection.



**Ensure that the plug will be accessible after installation.**

## How do you program for immediate cooking?

### Operating principle

The water contained in the tank arrives in the cavity via a pipe. This water is transformed into steam when it comes into contact with a hot surface located in the lower part of the cavity: this is the steam generator. There is no need to add water to the cooking dish. To guarantee REAL STEAM COOKING, your oven is furnished with specially designed cookware that will allow for perfect cooking.

- ⚠ You MUST fill the water tank to the **Max.** level before cooking. Return the tank to its housing by firmly pushing ALL THE WAY until you feel the tank LOCK INTO POSITION.
- ⚠ When in use, the appliance becomes hot. Hot steam will escape when you open the door of the appliance. Keep children away.

### Steam cooking

Steam cooking at 100°C

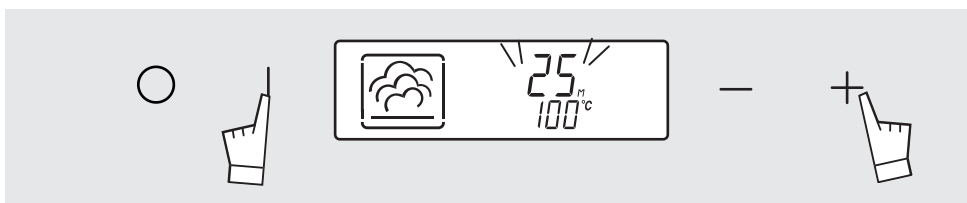



**1** Press the "Start" touch control. A cooking time of 25 minutes is suggested.

**2** Set the desired length of time (minimum is five minutes and maximum is 60 minutes) by pressing the + and - touch controls.

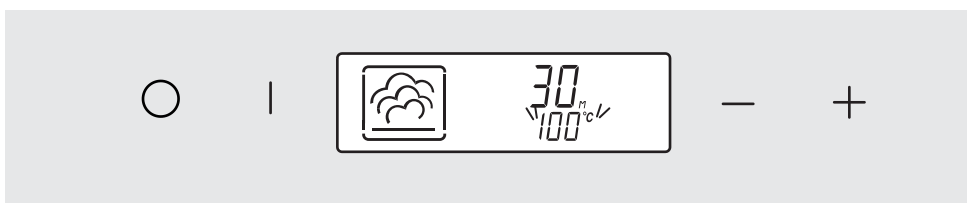
**3** Enter by pressing the "Start" touch control.



**4** The  symbol is activated. When the temperature has been reached, the 100°C display stops flashing and a beep is emitted.

 To avoid compromising the cooking results, do not open the appliance door during cooking.

### **Changing the cooking time**

During cooking, you can adjust the cooking time by pressing the + or - touch controls.

### **Cancelling cooking in progress**

You can stop the cooking at any time by pressing the Off touch control (press and hold for approximately one second).

If steam generation has not yet begun (approximately one minute), the oven stops immediately and the time disappears.

If steam generation has already begun, the time converts to three minutes; a countdown begins and the steam escapes before the door is opened.

### **At the end of a cooking programme**

0m00s is displayed. The display animation ceases. Discontinuous beeps are emitted for three minutes. To silence the beeps, press the Off touch control or open the door.

**The fan will continue operating for approximately 3 - 5 minutes after the door is opened.**

### **Keeping food warm**

As soon as the steam removal phase has been completed, you can keep dishes warm in the oven area. Press the stop button. The audible signal and display are then deactivated. Do not open the door. Dishes are kept warm and the fan operates at the same time until the door is opened.



**The dishes and plates used in the steam cooking will be hot.**



**You MUST empty the tank.**



In order to guarantee good oven reliability, the fan continues to function for a short period after cooking is complete.

## Locking display

It is possible to lock the display. This feature cannot be used during timed cooking programmes.

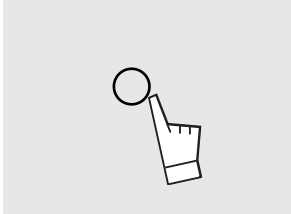

**1** Press the "Off" touch control for a few seconds.

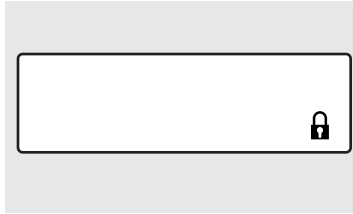

**2** A beep is sounded and a "padlock" appears on the screen. From this moment on, no touch control is active.

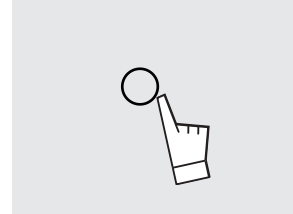

**3** To unlock the display, press the "Off" touch control for a few seconds: a beep is sounded and the padlock disappears.

## Water management

In the event of a water circuit-related problem during cooking, the "no water" indicator appears and a beep is emitted.



This error is specifically associated with:

- An empty tank.
- A poorly seated tank.

After checking these two items, cooking automatically restarts as soon as the door is closed.

## Cooking chart

VEGETABLES	TIMES <small>Regardless of quantity</small>	PREPARATIONS	NOTES
Artichokes (small)	<b>40 to 45 min.</b>	placed upside down in the dish	<ul style="list-style-type: none"> <li>• These times are a function of the type, size and freshness of the vegetables. Follow the indications that appear in the "Preparations" column.</li> <li>• The cooking time remains the same regardless of the quantity to be cooked. <i>Example:</i> 1 or 4 artichokes require the same cooking time.</li> <li>• To check if food is cooked pierce with the tip of a knife. If there is no resistance, the food is cooked.</li> </ul>
Asparagus	<b>35 to 40 min.</b>	for tips decrease cooking time	
Broccoli	<b>18 min.</b>	in small bunches	
Carrots	<b>20 to 22 min.</b>	in thin, round slices	
Celery root	<b>25 to 30 min.</b>	in thin slices	
Pumpkin	<b>15 to 20 min.</b>	in cubes	
Mushrooms	<b>15 min.</b>	in thin strips	
Puff pastry	<b>30 to 35 min.</b>	Brussels sprouts	
	<b>22 min.</b>	Cauliflower in small bunches	
	<b>30 to 35 min.</b>	Chopped green cabbage	
Courgettes	<b>10 to 15 min.</b>	in round slices	
Chinese artichokes	<b>20 min.</b>		
Spinach	<b>20 min.</b> <b>35 min</b>	(fresh) stir while cooking (frozen) " "	
Endives	<b>30 min.</b>	core removed, cut in half lengthwise	
Fennel	<b>22 min.</b>	cut in half	
Green beans	<b>30 to 35 min.</b>		
Turnips	<b>15 to 20 min.</b>	in cubes	
Fresh peas	<b>20 to 25 min.</b>	/	
Leeks	<b>25 min.</b>	cut in half	
Potatoes	<b>25 min.</b> <b>40 to 45 min.</b>	cut in round slices whole	
SHELLFISH CRUSTACEANS	TIMES	PREPARATIONS	NOTES
Sea scallops	<b>10 to 12 min.</b>	with seasoning	<ul style="list-style-type: none"> <li>• Place the scallops on the grid of the glass dish, add aromatic herbs.</li> <li>• Place the crustaceans on a bed of seaweed.</li> </ul>
Mussels/periwinkles	<b>20 to 25 min.</b>	with seasoning	
Crabs	<b>25 min.</b>	/	
Lobsters	<b>30 to 35 min.</b>	depending on weight	
Crayfish	<b>12 to 15 min.</b>	/	
FRUITS- PUDDINGS	TIMES	PREPARATIONS	NOTES
Apples/pears/ peaches	<b>10 to 15 min.</b>	whole, peeled	<ul style="list-style-type: none"> <li>• Times depend on ripeness.</li> </ul>
Compote	<b>25 min.</b>	fruit in strips	
Puddings	<b>10 min.</b>	in ramekins	

FISH	TIMES	PREPARATIONS	NOTES
Northern pike	<b>25 to 30 min.</b>	whole (1 kg)	<ul style="list-style-type: none"> <li>• *Steaks: Round slices of fish of 2 to 3 cm in thickness (180/200g) per person.</li> <li>• Insist on very fresh products.</li> <li>• Place whole fish in the dish as is or on bay leaves, fennel or other aromatic herbs.</li> <li>• As soon as cooking is complete, remove the skin, which will detach easily.</li> </ul>
Cod	<b>13 to 15 min.</b>	steaks (180 g)*	
Sea bream	<b>20 to 25 min.</b>	whole (1kg)	
Haddock	<b>15 min.</b>	filets	
Herring	<b>20 min.</b>	whole (200 g)	
Pollack/black cod	<b>15 to 20 min.</b>	steaks (180 g)	
Monkfish	<b>15 min.</b>	depending on thickness	
Mackerel	<b>20 min.</b>	whole (250 g)	
Atlantic cod	<b>15 min.</b>	filets	
Skate	<b>25 to 30 min.</b>		
Red mullet	<b>15 min.</b>	whole (200 g)	
Red mullet	<b>10 min.</b>	filets	
Spotted dogfish	<b>20 min.</b>	thick steaks (6 to 10 cm in length)	
Salmon	<b>15 to 20 min.</b>	steaks (180/200 g)	
Sole	<b>10 to 12 min.</b>	filets	
Tuna	<b>20 to 25 min.</b>	steaks (180/200 g)	
Trout, whole (1 kg)	<b>20 to 25 min.</b>	whole (200 g) <b>13 to 15 min.</b>	
MEATS/ EGGS	TIMES	PREPARATIONS	NOTES
Beef	<b>15 to 30 min.</b>		<ul style="list-style-type: none"> <li>• Then brown under the grill in another dish.</li> </ul>
Pork (filet mignon)	<b>25 min.</b>	Roast 800 g: <b>55 to 60 min.</b>	
Poultry (breasts, filets) (stuffed)	<b>20 to 25 min.</b>	Chicken thighs: <b>35 to 40 min.</b>	
Sausages	<b>25 min.</b>	Roast turkey: <b>50 to 60 min.</b>	
Boudins	<b>20 min.</b>	400 g piece	
<b>Eggs</b> start with very fresh eggs kept at room temperature	<b>7 min.</b> <b>5 to 6 min.</b> <b>8 min.</b> <b>10 to 12 min.</b>	<u>Soft-boiled</u> : placed directly on the grid. <u>Fried</u> : broken in an individual dish placed on the grid and covered with cooking wrap. <u>Medium-boiled</u> : placed directly on the grid. <u>Hard-boiled</u> / <u>poached</u> : see detailed recipes.	
RICE, PASTA FARINA	TIMES	PREPARATIONS	NOTES
Place directly in a dish then cover with water or milk. The steam is not enough to saturate these inflating foods. Place a sheet of aluminium foil on the dish to prevent water droplets from falling in.			
Rice pudding	<b>30 min.</b>	100 g rinsed rice - 20 cl milk - 2 T. sugar	<ul style="list-style-type: none"> <li>• Fluff with a fork when cooking is complete.</li> </ul>
Farina	<b>20 min.</b>	200 g (1/4 litre water)	

## Steam cooking

Steam cooking is not a recent invention, In Asian and particularly Chinese cooking, delicate steam cooking has been practised for a long time. One of the advantages of this type of cooking is that the foodstuffs do not remain in contact with the cooking juices. Consequently, the vitamins and minerals are particularly well preserved, but also the delicious taste of the food. The principle of steam cooking is simple: by heating it up, water is transformed into steam and transmits its heat to the food located in the cooking dish. Because the food is not placed directly in boiling water, less is taken out of it. In other words, the loss of mineral elements and vitamins is minimised. Consequently the taste of the food is also better preserved than with any other cooking method. As a result, seasoning with salt can be considerably reduced. Additionally, steam cooking does not require the use of fats. This therefore makes it the ideal cooking method for those looking to enjoy healthy cookery. Even if steam cooking is an extremely delicate method, the technique is the same as for other cooking methods. The food must be prepared (especially vegetables) and then washed, and finally cut into pieces just before steam cooking.

### Steam cooking tips

Water is a liquid, well adapted to steam cooking. **Fatty liquids such as stock or sauces will stick and cling to the inside of the oven.** Sauces can be subsequently prepared using the cooking juices, and the dish can then be sprinkled with 2-3 tablespoons of white wine etc. All foods can be slightly seasoned before steam cooking. It is not necessary to use a great deal of salt as the taste of the food already comes to the fore during steam cooking. Fresh herbs, finely chopped vegetables or marinades can also be used to spice up dishes. Leftover rice, pasta, potatoes and vegetables can be gently reheated using steam. Dishes covered with sauces or stock can be given a new lease of life! The heating time is between 10 and 20 minutes according to the dishes. You can also use the steaming method to gently defrost certain frozen products. Frozen vegetables, fish or meat can be defrosted directly by steam. Place the ingredients as flat as possible on the cooking dish.

### Cooking tips

**Caution! Take care when opening the appliance during the steam cooking process. The steam given off is hot and can burn you!**

### Cooking fish using steam

During steam cooking, fish remains juicy and firm, with the tastes and characteristics of the various types of fish being particularly well conserved. Fillets and whole fish are well suited to this cooking method. The cooking times using steam are very short. The fish is cooked when the skin is no longer shiny and it can be cut using a fork. Before use, you should slightly coat the inside of the cooking dish with butter or oil to ensure that the tender skin of the fish does not stick. Fish is particularly aromatic when the cooking dish is covered with a layer of fresh herbs (for example sprigs of thyme or dill), finely chopped aromatic vegetables or condiments such as finely chopped onions, garlic, sliced ginger or slices of lemon, etc. Additionally, we

recommend that you marinate the food before steam cooking. As examples, lemon juice, olive oil, white wine or soya sauce all add plenty of taste to your fish dish.

### **Cooking meat using steam**

Only the most tender pieces such as fillets of veal, pork or beef, or white chicken meat (perfect for this type of preparation) can be steam cooked. They remain particularly juicy when rolled in leaves (for example spinach) or cooked on a bed of vegetables. Where meat is concerned, it is particularly important to avoid overcooking it, which will lead to it becoming dry and hard. It is better to reduce the cooking time indicated and check if the meat has already cooked sufficiently. It is always possible to continue cooking for a little longer if you find the meat isn't done enough but it is never possible to improve the quality when the meat is overcooked! Steam cooked meat always requires a spicy seasoning to avoid it becoming bland. For this reason, we recommend that you add a sauce.

### **Poaching food in the steam oven**

Steam cooking (which will be new to many of you) can in certain cases also replace the use of a double boiler. Preparing food using steam cooking is ideal for flans and terrines. However, the ingredients should never be added directly into the cooking dish but instead cooked in moulds. Porcelain and glass moulds resist heat well and are particularly well suited, unlike plastic moulds. The cooking times can vary slightly according to the size and material used for the moulds and/or their ability to conduct heat.

### **Sterilisation in the steam oven**

You can also use your steam oven to sterilise all the fruit and vegetables that you have conserved up until now using classic methods in a sterilisation recipient or the oven. You can simultaneously conserve the contents of 4 x 750 ml jars (height: 14 cm). Wash the jars carefully and use new elastic rings.

**Vegetables:** wash, prepare and blanch in the steam oven for around 10 to 15 minutes. Cool using ice cold water and place immediately in the glass jars (to a level of 3 cm below the rim) and fill with a solution of salt (1 litre of water + 1 tablespoon of salt brought to boiling point) up to three quarters of the jar's height. Fit a damp rubber ring and close using the cover and hook. Tomatoes should be inserted raw. Add fresh herbs to carrots. Add a little lemon juice to apples and pears.

**Fruit:** wash, prepare and fill the jars up to a level of 3 cm below the rim. Fill using a sugary solution (1 litre of water + 150 - 250 g of sugar, brought to boiling point) up to two-thirds of the jars height. Fit a damp rubber ring and close using the cover and hook. Once the sterilisation time is up, you should turn off the steam oven, open the door for approximately 10 seconds and then leave to stand for around 30 minutes in the closed steam oven.

## How do you care for your oven?

### **Maintenance**

#### **Cavity** (after each use)

Wipe the cavity with a dry cloth after the steam generator has cooled or let the cavity air-dry by leaving the door open.

#### **Water pipe** (once a month)

Remove the water pipe by pulling it towards you. Remove any hard-water deposits that may be inside (using a thin, pointed object such as a thick skewer or a knitting needle).

#### **Steam generator** (once a month)

Pour 1/2 cup of white vinegar on the generator. Let sit for a few minutes, then clean and rinse with water. Do not use sponges or abrasive powders, nor coffee maker cleaning agents.

### **Cleaning the Gutter**

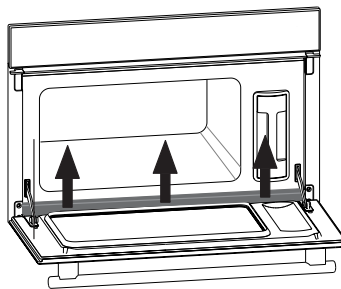

Remove this gutter by pulling it upward. Wipe it off and return it to its position using the three notches provided.

 **The oven should not be cleaned with a steam cleaner.**

## Cleaning the oven cavity

### Safety during cleaning

- During manual cleaning, ensure that the oven is sufficiently cool before touching any of the internal parts.
- Always keep your steam oven clean.
- Check that the door and frame seals are clean.
- You risk injuring yourself if you attempt to remove the door from the hinge. Consequently, the assembly and dismantling of the door should only be carried out by a technician from the After Sales Service Department, trained in this field.
- During cleaning, you must not use high-pressure or steam cleaning appliances for reasons related to electrical safety.

### Cleaning and maintenance

Ensure that the oven cavity and the steam generator have cooled sufficiently before touching them. Only the lighting for the oven cavity can be turned on.

**⚠ During cleaning, you should not use steam cleaning or high-pressure appliances for reasons inherent to electrical safety. You should not use chlorine-based products, products designed to decalcify electrical household appliances powders or sponges.**

For hygiene reasons, it is recommended that you empty and clean the interior of the oven, the drip channel and the reservoir after each use. To do so, use a damp sponge. You should subsequently wipe dry with a cloth (synthetic). Remove any possible limescale deposits with vinegar. Allow to act for a few minutes, clean and rinse with water.

**⚠ Ensure that you keep the surface of the seals clean around the doors and its frame, checking that this seal has not become dislodged from its support.**

The control panel and the front part of the door should be cleaned using a mild detergent and then wiped.

## Cleaning the oven cavity

During cleaning, ensure that you do not wipe the surface of the stainless steel in the wrong direction (the "grain" runs horizontally).

**Do not use circular movements!**

Remove any slight impurities with the aid of a soft, clean and damp cloth (microfibre cloths are particularly well suited for this task).

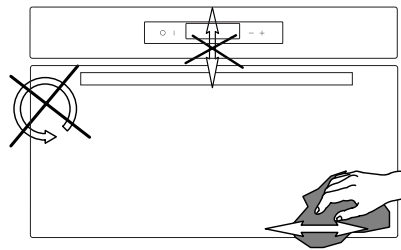

Scraping tools or scouring products are not suitable.

In the event of major soiling, you can use household cleaning products designed for stainless steel. Be sure to observe the manufacturer's instructions when using these cleaning and maintenance products.

## Changing the bulbs

 **Before removing the bulbs from the housing, be sure to first turn off the electrical supply to the appliance. Turn off the oven and/or activate the cut-out or unplug the power lead.**

You can replace any defective incandescent bulbs yourself.

You need to obtain bulbs able to withstand a temperature of 300°C, 25 watts, 230 - 240 volts, E14, which can be purchased from shops specialising in electrical items.

 **Caution!**  
**Do not damage the seals!**

1. Turn the cover of the lamp to the left.
2. Turn and unscrew the incandescent lamp in an anti-clockwise direction.
3. Replace the incandescent lamp.
4. Reinsert the cover, screwing it in a clockwise direction.

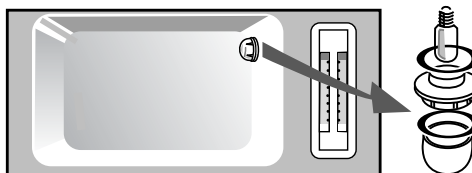

 **Ensure that both seals are in the right place.**  
**Caution!**  
**The seals must be in perfect condition. In the event that the seals are damaged, please contact the After Sales Service Department.**

## What to do in case of malfunctions?

YOU OBSERVE THAT...	POSSIBLE CAUSES	WHAT SHOULD YOU DO?
Your display does not light up	<ul style="list-style-type: none"> <li>- Oven is not connected to power source.</li> <li>- Electronic board is not functioning.</li> </ul>	<ul style="list-style-type: none"> <li>- Check that the appliance is receiving electricity (good fuse).</li> <li>- Call the After-Sales Service Department.</li> </ul>
Water or steam leak around the door during cooking.	<ul style="list-style-type: none"> <li>- The door is not properly closed.</li> <li>- The door seal is defective.</li> </ul>	<ul style="list-style-type: none"> <li>- Call the After-Sales Service Department.</li> </ul>
The steam oven does not work.	<ul style="list-style-type: none"> <li>- A power supply problem.</li> <li>- The electrical system is faulty.</li> </ul>	<ul style="list-style-type: none"> <li>- Put the plug into the plug socket.</li> <li>- Check the cut-out.</li> <li>- Call the After Sales Service Department.</li> </ul>
The light on the oven cavity does not work.	The light is faulty.	Replace the light.
Water or steam comes out of the appliance.	<ul style="list-style-type: none"> <li>- The door is not properly closed.</li> <li>- The door seal has come away from its support.</li> <li>- The door seal is faulty.</li> </ul>	<ul style="list-style-type: none"> <li>- Close the door properly.</li> <li>- Correctly insert the seal into its support.</li> <li>- Call the After Sales Service Department.</li> </ul>
There is residual water in the oven cavity on the inner door and the door seal.	This is normal.	Dry with a cloth.
The drip channel fills with water after every cooking session.	<ul style="list-style-type: none"> <li>- The seal on the tank is faulty.</li> <li>- The seal on the door has come away from its support.</li> <li>- The seal on the door is faulty.</li> <li>- The door is sloping.</li> </ul>	<ul style="list-style-type: none"> <li>- Replace the seal.</li> <li>- Correctly insert the seal into its support.</li> <li>- Call the After Sales Service Department.</li> <li>- Call the After Sales Service Department.</li> </ul>

**In all circumstances, if your efforts are not sufficient, contact the After-Sales Service Department without delay.**

## How to contact us?

Copy here the details that are on your oven manufacturer's plate:

<b>Kleenmaid</b> MADE IN FRANCE	BRANDT APPLIANCES SAS 7 rue Henri Becquerel 92500 RUEIL MALMAISON	N° SER. <input style="width: 80%;" type="text"/>	
220 - 240V ~ 50 Hz		REF. <input style="width: 80%;" type="text"/>	
		TYPE <input style="width: 80%;" type="text"/>	CONS.N°214



## WARRANTY AND SERVICE

### DOMESTIC WARRANTY - FULL FIVE YEAR WARRANTY

In addition to all statutory rights which you, the Consumer, have under the relevant laws in respect of this appliance, during the first five years of ownership as the original purchaser of this Kleenmaid appliance, we guarantee that any fault caused by faulty material or workmanship becoming apparent will be rectified free of charge for parts and labour, provided that all service is performed during normal working hours by Kleenmaid or their designated Agents. Where the appliance is installed outside the normal servicing area of the above, the Purchaser must pay for the cost of transporting the appliance to and from the Agent or the Agent's travelling cost to and from the Purchaser's home.

### COMMERCIAL WARRANTY - ONE YEAR WARRANTY

When this appliance is installed in a commercial application, you, the Consumer, have under the relevant laws in respect of this appliance, during your first one year of ownership as the original purchaser of this Kleenmaid appliance, we guarantee that any fault caused by faulty material or workmanship becoming apparent, will be rectified free of charge for parts and labour, provided that all service is performed during normal working hours by Kleenmaid or their designated Agents. Where the appliance is installed outside the normal servicing area of the above, the Purchaser must pay for the cost of transporting the appliance to and from the Agent or the Agent's travelling cost to and from the Purchaser's home.

### WHAT THESE WARRANTIES DO NOT COVER

We are not responsible for any damage or malfunction unless caused by a defect in material or workmanship. This includes but is not limited to abuse, misuse, improper installation and transportation damage. We are not responsible for any consequential damages from any malfunction.

The Consumer must make the appliance available for servicing and shall bear any costs incurred for any de-installation and/or re-installation required to make the appliance available for servicing. Kleenmaid is not liable for any consequential damage incurred during de-installation or re-installation.

### WARRANTY DOES NOT COVER REPLACEMENT OF LIGHT GLOBES OR GLASS BREAKAGE DUE TO IMPACT

In case of fractured glass do not use your appliance.

### WARRANTY REGISTRATION

Please complete warranty details below and retain together with your proof of purchase document. These documents will need to be viewed by our Service Representative should you request in warranty service.

### SERVICE ASSISTANCE

To assist you when phoning our After Sales Service number to arrange a service call please complete the following details and have them ready when you call.

Model Number \_\_\_\_\_ Date of purchase \_\_\_\_\_

Kleenmaid Store purchased from \_\_\_\_\_ Date of installation \_\_\_\_\_









Other products available in the **Kleenmaid**  
Range of appliances

Washers

Dryers

Dishwashers

Ovens

Cooktops

Outdoor Cooking Centres

Built In Espresso Coffee Machines

Rangehoods

Freestanding Ranges

Sinks

Waste Disposals

Taps

Cookware

Refrigerators

Freezers

Wine Cellars

Vacuum Cleaners

For sales information on the full range of quality appliances  
Phone 13 13 08

 **Kleenmaid**  
The best you can own.

99636251 02/05

Modus

