

SCALA OVEN

Models

- TO2A - Stainless Steel Single Oven
- TO21A - White Single Oven
- TO22A - Black Single Oven
- TO23A - Mirror Single Oven

Owner's Manual

SCALA OVEN

Introduction

Congratulations on your purchase of a Kleenmaid appliance.

You have chosen a quality product which has a 3 year parts and labour warranty, and to assist you with the use and care of your appliance you are entitled to a free in-home demonstration.*

This booklet is a guide to help you achieve the best results from your cooking appliance, but like all new products, you will need to get to know your oven, and you may need to modify your traditional cooking techniques to achieve the best cooking results.

We're sure you will enjoy using your Kleenmaid oven and we invite you to contact us on 1-800-072-144 (freecall) should you require any further information, or if you would like to organise your free in-home demonstration.

Yours sincerely,



*Andrew Young
Joint Managing Director*



*Dick England
Joint Managing Director*



**In-home demonstrations may not be available to purchasers who live outside our usual service areas. Please phone us on 1-800-072-144 to find out if a Kleenmaid Demonstrator operates in your area.*

SCALA OVEN

Table of Contents

	PAGE NO.
Installation	2a-2b
Inclusions	3
Control Panel	3
Oven Functions	4
Advanced Oven Features	5
Electronic Timer	6
Defrost Function	10
Normal Baking Function	11
Fan-Forced Baking Function	14
Roast by Time and Weight	17
Grilling Function	18
Fan Grilling Function	20
Grilling Chart	22
Patisserie Function	23
Multi-Function Cooking Guide	24
Free In-Home Demonstration	25
Removing the Door	25
Cleaning the Oven	26
Drop Down Grilling Element	26
Changing the Light Bulb	27
Appliance Warranty Details	28
Metric Conversions	Back Cover

SCALA OVEN

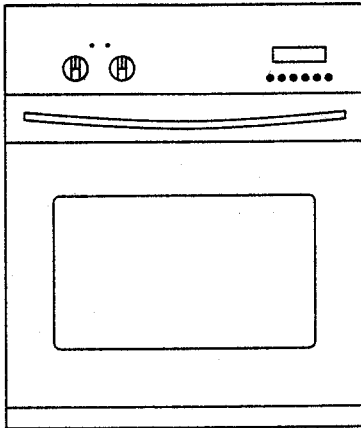

Model Description

- TO2A Stainless Steel Single Oven
- TO21A White glass front Single Oven
- TO22A Black glass front Single Oven
- TO23A Mirror glass front Single Oven

Installation

IMPORTANT: Connection to electrical mains must only be performed by a licensed electrical contractor. All care must be taken to ensure the installation is properly earthed and conforms to all local codes.

Use the 6 screws and washers provided to secure the front trim side rails to the cabinet front to ensure safe usage. Take extra care when screwing through the enamelled frame not to overtighten causing enamel damage.

Kleenmaid ovens may be installed in any type of heat resistant cabinet (eg. timber finished in plastic laminate, timber, metal, brickwork etc).

When installed as a wall unit, ensure that the upper-rear section of the cabinet has a minimum 20mm depth vent.

Note: Any vertical cupboard panels immediately beside the wall oven must be sealed completely to obtain the best results from your oven.

DO NOT use the door as a lever to assist with installation into its recess. Undue pressure must never be placed on the oven door when it is open.

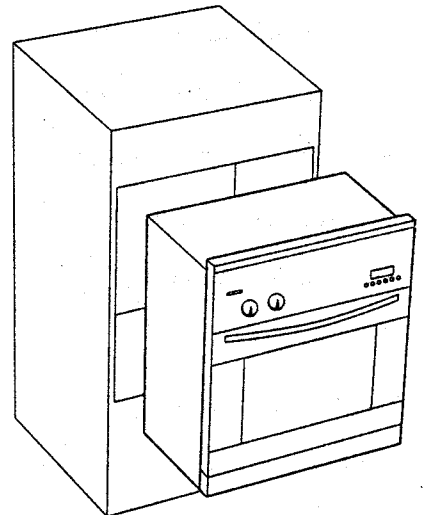

MODELS TO-2A, TO-21A, TO-22A, TO-23A

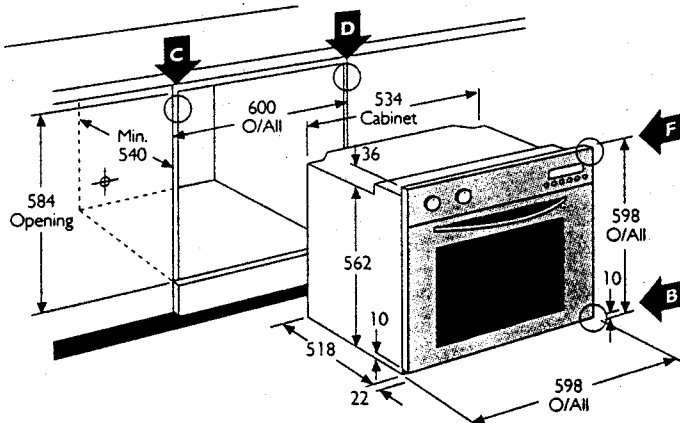

Kleenmaid Scala Oven's unique fan cooling system ensures the oven control panel and handle remain cool to touch. The cabinet should be constructed as a box surrounding the oven using fully sealed materials and allowing for a venting cavity at the rear.

Model	Oven Capacity Litres	Electrical	Approval No.	Installation Method	Dimensions		
					H	W	D
TO-2A TO-21A TO-22A TO-23A	52	240V AC 11A 2640W	W2263	Flush	584	600 Overall	540
				Proud	Not Recommended		
<small>N.B. Illustrations in this brochure show "Flush Mounted" dimensions.</small>							

Kleenmaid's continuing commitment to quality products may mean a change in specifications without notice. Please contact 1800 072 144 before commencing cabinet construction.

KLEENMAID

FREE INFO HOTLINE: 1800 072 144

SCALA OVEN

Inclusions

- 1 x shallow enamelled baking tray
- 1 x enamelled roasting/grilling pan with rack
- 2 x enamelled baking trays
- 2 x oven racks

Control Panel

1. Multi-function selector dial - for the selection of various cooking options.
2. Red indicator light - this light indicates when a cooking function has been selected.
3. Yellow indicator light - this light indicates when the oven heating elements are energised. It will turn off when the desired temperature is reached, then on again each time the thermostat indicates more heat is required.
4. Thermostat - controls the cooking temperature.
5. Electronic Control Clock - provides various timing functions from minute-minder to fully automatic cooking.

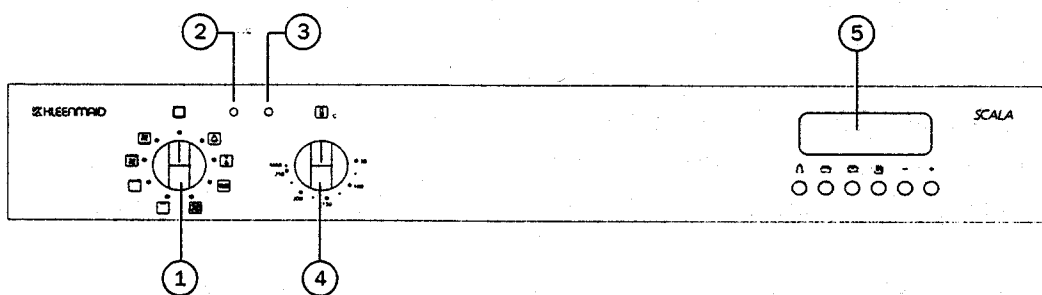

Oven Capacity









Multi-function Oven 52 litre.

When you first use your oven, the oven will need to "settle". That is, it needs to burn off production residues and dust. The metal used in the oven will also expand slightly when first used. You will experience some crackling and a strong smell. This is perfectly normal and we advise you anticipate this "settling" prior to use. Using an empty oven, select Function 4 and set a temperature of 250°, allow the oven to "settle" for 1/2 hour, turn to Function 3 and heat for a further 1/2 hour.

SCALA OVEN

Kleenmaid Scala Multi-Function Oven Function Selections

(Model Nos. TO2A, TO21A, TO22A, TO23A)

1.  **Light** - The light illuminates the oven during normal cooking modes, and assists you when cleaning the oven.
2.  **Defrost** - This function activates the fan only, (no heat is used) to allow controlled and hygienic defrosting.
3.  **Conventional Cooking** - Normal or traditional cooking function using the top and bottom elements. When using this function set the thermostat between 50 - 250°C. When the desired temperature is reached the red light will go out and then alternate between lit and unlit as the temperature is controlled.
4.  **Fan-forced Cooking** - This selection is best for multi-level cooking as the heat generated by the central element is circulated around the oven, creating an even heat environment. You will need to set the thermostat dial between 50 - 250°C for this function.
5.  **Centre Griller** - For best results set the thermostat to MAX. (The door may remain closed or completely open.
6.  **Large Griller** - For best results set the thermostat to MAX (The door may remain closed or completely open.
7.  **Fan Griller** - This function combines the grill element with fan assistance and is used in conjunction with the thermostat. The oven door must remain CLOSED during cooking. The thermostat dial should be set between 50 - 250° for this function.
8.  **Fan-assisted Baking or Patisserie Setting** - Combines the concealed bottom element with fan assistance and is used in conjunction with the thermostat. The oven door must remain CLOSED during cooking.

SCALA OVEN

Advanced Oven Features

Cavity Cooling

The Kleenmaid Scala oven has an advanced cavity cooling system. A cylindrical fan is mounted on the rear outside frame of the oven. This fan assists the movement of air through the oven cavity keeping it cool. In addition to reducing the temperature in the oven cavity, the air is blown out around the oven door handle which keeps the door handle cooled. The cooling fan is activated when the oven light or any cooking function is selected and will switch off after all oven functions have been turned off.

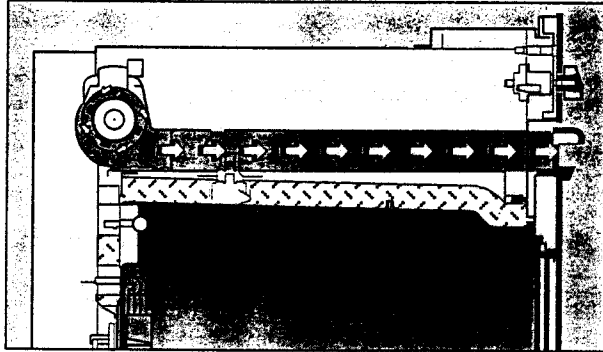

Triple Reflective Door Glazing

The Kleenmaid Scala has two levels of removable door glass. The two inner layers are removable and are made of a reflective glass which, in effect, reflects heat back into the oven and results in a significant reduction in the outside door surface temperature. The glass is easily removed for cleaning. Use a 10 cent coin to loosen the screws, then remove each layer to clean. Ensure the narrow air gap lies between the inner and centre glass layers and the wider gap lies between the centre and outside glass layers. When replacing the glass ensure that the rubber gasket is placed around the centre glass layer so that the narrow air gap lies between the inner and centre glass. Do not overtighten screws when replacing the glass.

Wipe Clean Enamel

The baking trays and grill pans supplied with your oven are finished in the soft-grey super tough "wipe clean" enamel.

This enamel is less porous than conventional, so that food does not adhere as easily. Simply wipe clean with a soapy cloth or creme cleanser when cooking is finished.

For baked on residue, use a scraper or if necessary a non-caustic oven cleaner

Drop Down Grill Element

The removal of a single screw at the front of the upper grill element allows the element to drop down so that cleaning the ceiling of the oven is made easy. On completion of cleaning, simply replace the grill element and secure with the screw, finger-tight.

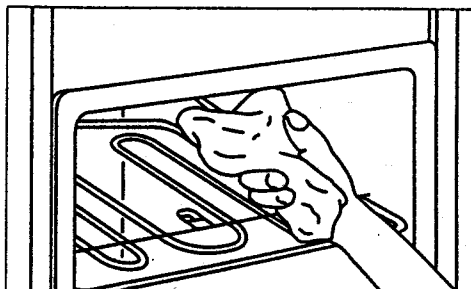
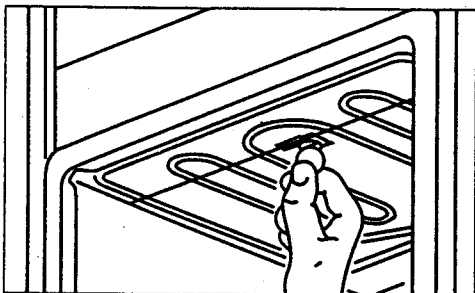

SCALA OVEN





The Electronic Timer

Note: Automatic cooking functions are possible using the electronic programmer.

The electronic timing control on your Scala oven provides more options than simple manual cooking i.e.





- Countdown timer for precise timing needs;
- Normal manual cooking
- Semi-Automatic. "Start Now - Stop Later".
- Fully Automatic. "Start Later - Stop Later".

The 24 hour clock allows you to set your automatic cooking options up to 24 hours in advance.

1.  Countdown Timer and Alarm Bell Button
2.  Cooking Duration Button
3.  Finish Cooking Button
4.  Manual Operation Button
5. - Minus Time Button
6. + Plus Time Button

Setting the Time on the 24 Hour Clock

The clock will require setting when you first turn on the power (or following a power failure).



1. The AUTO symbol and the time 0:00 will flash;
2. Hold down the  button and  button simultaneously whilst using the "+" button to set the time of day. The time will advance slowly, then speed up. (If you over-shoot the desired time, use the "-" button). Once the desired time has been reached, release all of the buttons (the time you have set will disappear for a moment and then reappear with the AUTO symbol flashing beside it).
3. Press the  button to set the oven for manual cooking. The AUTO sign will disappear and the  symbol will appear in the middle of the time displayed.

THE OVEN IS NOW READY FOR USE AND TO ACCEPT THE DESIRED COOKING FUNCTIONS.

SCALA OVEN

Using the Countdown Timer

The timer can be set for any time up to 24 hours and will count down to zero. When it reaches zero a high-pitched alarm will sound. To set the Countdown Timer:

1. Depress the  button and release to show 0:00. Using "+" button advance the timer to the desired time.
2. Once the Countdown timer is set, the normal time of day will return to the display within 4 seconds.
If you wish to check how much time remains on the Countdown, simply depress the  for a moment. The remaining time will be displayed. After 4 seconds the normal time will return to the display.
3. To silence the alarm press the  button.

Adjusting the Tone of Timer Bell

It is possible to adjust the tone of the beeper that comes from the electronic clock. To do this simply press the minus button, once your desired tone is reached release the button.

Manual Cooking

Once the time of day is set the  symbol will be displayed. The oven is now in manual operation mode ready for you to select the desired cooking function and temperature.



SCALA OVEN

Automatic Cooking Modes

Note: We suggest that the desired temperature and cooking function be set prior to the programming of any AUTO function.

Semi-Automatic (Start Now - Stop Later):



A) Based on setting the duration

1. Set the function and temperature to the desired position.
2. Let's say you wish to cook for 45 minutes. Press and release the  button. For 4 seconds the 0:00 symbol will be displayed. During this time you need to set the duration cooking time of 45 minutes by pressing the "+" button (use the "-" button should you over-shoot the required time). Release and the display will return to the normal time of day. The AUTO symbol will also appear indicating that you have set the automatic cooking function.
3. The oven will operate for 45 minutes only, turn off automatically and the alarm will sound. The AUTO symbol will flash and the  symbol will disappear. The alarm will turn off soon after. To silence the alarm immediately, press any button except "+" or "-".
4. When you press the  button, the oven will return to normal cooking mode.

If further cooking is required, either leave on manual or repeat the above setting sequence.

Note: If you have not turned the function and thermostat settings off your oven will now continue to operate manually. The AUTO symbol will disappear and the  symbol will reappear.

B) Based on setting a cook stop time



1. Set the function and thermostat control to the desired position.
2. Let's say you commence cooking and decide you would like the oven to turn off at 6.00pm. Press and release the  button; the display will show no change. Press the "+" button within 4 seconds and advance to the desired completion time of 6.00pm, ie 18:00 on the 24 hour clock. The AUTO symbol will be illuminated.
3. The oven will continue to cook until 18:00 (6.00pm) and then switch off. The AUTO symbol will flash and the alarm will sound. Silence the alarm by pressing any of the buttons except "+" or "-".
4. Press the  button to return to manual cooking.

Note: If you have not turned the function and thermostat settings off your oven will now continue to operate manually. The AUTO symbol will disappear and the  symbol will reappear.

SCALA OVEN

Fully Automatic - (Start Later - Stop Later)

Your Scala oven may be programmed to start, cook for the desired time and turn off automatically. This function is particularly useful in the preparation of the evening meal. Should you be out during the day, it will be ready on your return home. For example if your cooking time is 45 minutes and you want the cooking to finish at 6pm.

1. Press the  to set the cooking duration time for say 45 minutes using the "+" or "-" buttons. Release and the display will return to the normal time of day.
2. Next, press the  time and set at, 6.00pm (18:00). Release and the display will return to the normal time of day. The AUTO symbol will be displayed.

Using the above settings, the oven is now programmed automatically to commence cooking 45 minutes prior to 6.00pm then automatically turn off.



When cooking is complete, the AUTO symbol will flash and the alarm will sound. You may silence the alarm by pressing any button except "+" or "-".

3. Press the  button to return to manual cooking.

Note: Don't forget to turn off the cooking function and thermostat if cooking is complete as pressing the  button will result in the oven continuing to operate manually.

Cancelling Automatic Settings

To cancel a programme:

- Step 1: Press the  button, and scroll back to 0:00 using the "+" or "-" button. The AUTO symbol will begin to flash on the display.
- Step 2: Press the  button to return to manual cooking.

SCALA OVEN

Multi-Function Oven Settings

Defrost

Function 2: The defrost setting allows natural thawing for delicate foods such as fine pastries, desserts, bacon slices and seafood. Rather than leaving them on a benchtop they may be defrosted in the closed hygienic environment of the oven.

DEFROST SUGGESTIONS:

This function is ideal for defrosting frozen meats and other freezer items, and particularly those items which require gentle defrosting such as:-

- Sara Lee desserts
- Bacon
- Fish fillets
- Bread
- Cakes, scones, etc

SCALA OVEN

Normal Baking

Function 3: Normal oven baking using heat from both the upper element and concealed lower element.

To bake, place the oven rack in the appropriate position according to the type of food to be cooked. Turn the Function Selector to Position 3 and the thermostat knob to the correct temperature, and allow the oven to fully pre-heat for best results.

Ideal for cooking casseroles, souffles, roast meats and other items which require a slower method of cooking.

RECIPES:

Impossible Quiche

Ingredients *1 cup milk*
 3 eggs
 1 tblsp melted butter
 Salt & pepper
 3 chopped bacon rashers
 1 chopped small onion
 1/2 cup self raising flour
 1 cup grated cheese

Method Combine milk, eggs, butter, salt & pepper in a bowl.
 Using another bowl mix bacon, onion, flour and cheese.

Combine both mixtures in a sealed container and shake vigorously for a couple of minutes. Pour into medium quiche dish. Place on the centre shelf and bake at 200° for 35 minutes.

Garnish with parsley.

Alternatives Tinned mushrooms, tomatoes and asparagus.

SCALA OVEN

Barbecued Chicken Drumsticks

- Ingredients *8 chicken drumsticks*
- Sauce:
- 1/4 tsp mild chilli powder*
 - 1 tsp celery salt*
 - 1 tsp salt (optional)*
 - 3 tblsp brown sugar*
 - 2 tblsp cider or vinegar*
 - 2 tblsp worcestershire sauce*
 - 3 tblsp tomato sauce*
 - 2 tblsp honey*
 - 2 tblsp sweet pickles*

- Method Pre-heat oven. Combine the sauce ingredients and heat until thickened.
- Coat the drumsticks with the sauce and place side by side in a flat dish. Pour remaining sauce over drumsticks.
- Bake on Shelf 2 at 200° for 35 minutes.
-

Muffins

- Ingredients *1 2/3 cups self raising flour*
- 2/3 cup sugar*
 - 2/3 cup milk*
 - 1 egg*
 - 30g melted margarine (or butter)*
 - 2/3 cup sultanas (or dates or raisins)*

- Method Pre-heat oven. Combine all ingredients.
- Place 2 tsp of mixture into a well greased muffin tin.
- Cook at 200° for 12-15 minutes on Shelf 4.

SCALA OVEN

Boiled Pineapple Fruit Cake

Ingredients *425g undrained unsweetened pineapple pieces*
 125g butter
 1 cup sugar
 250g sultanas
 125g chopped dates
 125g chopped glace cherries
 1 level tsp bicarb soda
 2 eggs
 1 cup plain flour } *Sifted together*
 Pinch salt
 1 cup self raising flour

Method

Pre-heat oven to 180°. Combine the undrained pineapple, butter, sugar, sultanas, dates and cherries in a saucepan and bring to the boil. Simmer for 15 minutes. Add bicarb soda and allow the mixture to cool.

Beat the eggs and stir into the cooled fruit mixture. Fold in sifted ingredients lightly and thoroughly. Turn into a 20cm tin which has been lined with a layer of brown and white paper.

Bake at 170° for 75-90 minutes on centre shelf.

Turn onto a wire cooler and cool completely before storing.

SCALA OVEN

Fan-Forced Baking

Function 4: Scala's fan-forced, central element cooking requires slightly different techniques and timing than normal cooking. The fan draws the air in and over the central element which is positioned around the fan and then circulates it back around the oven cavity. The even distribution of heat allows foods to rise and cook simultaneously regardless of shelf level. Lower cooking temperatures and in some cases less cooking time is another advantage of this feature.

Turn the Function Selector to Position 4 and turn the thermostat to the desired temperature. Pre-heating takes much less time than a normal bake oven.

Note: When cooking meats, for best results always pre-heat the oven to ensure the meat surface is sealed to lock-in juices for a moist and tender result.

Fan-forced cooking is ideal for multi-level cooking eg. patty cakes. Another advantage of fan-forced cooking is that different types of foods may be cooked simultaneously without mixing the aromas or flavours. When using the oven in this way, ensure that all the foods require the same cooking temperature and check the finish times of each dish for best results.

Please note that fan-forced cooking is faster than conventional methods, so take care not to burn your food when you first start using this method.

RECIPES:

Meat Parcel Surprises

Ingredients	<i>Puff pastry sheets</i> <i>Diced cooked meat pieces</i> <i>(mixed ham, bacon, salami & chicken - any meats are suitable)</i> <i>Diced onion, tomato, mushroom</i> <i>Grated cheese</i> <i>Tomato sauce (optional)</i>
Method	Mix all ingredients together. Cut pastry sheet into 4 squares. Place a small portion of mixture in the centre of each square. Fold corners of each square to a point and pinch pastry edges together. Place on a baking tray and cook at 200 - 220° for 12-15 minutes or until brown. Serve with salad or vegetables.

SCALA OVEN

Meat Loaf

Ingredients

1 kg lean minced beef
1 cup breadcrumbs
1 egg
1/3 cup red wine
Salt & pepper
2 tblsp tomato sauce
2 tblsp worcestershire sauce
1 tsp rosemary
1 tsp coriander
Diced onion

Basting mixture:

3 tblsp tomato sauce
3 tblsp worcestershire sauce
3 tblsp red wine
1 tblsp brown sugar

Method

Pre-heat oven to 180°. Place lean minced beef in mixing bowl and add breadcrumbs, egg, red wine, salt and pepper. Add tomato and worcestershire sauces, rosemary and coriander to taste.

In a separate pan, saute onion until clear and add to mixture. Mix thoroughly and mould into a loaf shape. Place on a greased tray.

Prepare basting mixture, by combining all ingredients in a cup.

Cook at 180° for 60 minutes. Baste liberally every 15 minutes.

Serve with mashed potato, honeyed carrots and greens.

SCALA OVEN

Rice Bubble Crunchies

Ingredients *125g margarine, softened*
 1 cup sugar
 1 tsp vanilla essence
 1 egg
 1 cup plain flour
 1/2 cup dessicated coconut
 1/2 cup sultanas or mixed fruit
 2 cups rice bubbles

Method In a large bowl, beat margarine, sugar and vanilla essence until light and creamy. Add egg and beat well. Stir in flour, coconut and sultanas, mix well. Using a teaspoonful of mixture, roll in rice bubbles. Coat well. Place on a lightly greased baking tray and flatten slightly. Bake at 160° for 15-20 minutes or until golden brown. Makes 15-20 biscuits.

SCALA OVEN

Roast by Time and Weight

APPROXIMATE ROASTING TIMES				
MEAT		TEMPERATURE °C	MINUTES PER 500g	INTERNAL TEMPERATURE °C
Beef	Rare	160	25-30	60-65
	Medium	160	30-40	73-75
	Well done	160	40-45	78-80
Veal	Well done	160	35-40	78-80
Mutton		160	35-40	82
Hogget Lamb	Fillets	160	25-30	79-80

Fan-Forced Cooking Conversion Chart

RECOMMENDED TEMPERATURE °C												
Fan-Forced	130	140	150	160	160	170	180	190	200	210	220	230
Normal Bake	140	150	160	170	180	190	200	210	220	230	240	250

SCALA OVEN

Grilling

Functions 5 & 6: During grilling the door may remain closed or completely open.

Functions 5 & 6 offer the traditional grilling method necessary to achieve proper browning without overcooking the interior of the foods.

Position 5 activates the centre section of the upper grill element only, which is ideal for browning smaller portions or thinner cuts of meat.

Position 6 activates the entire upper element for the grilling of large quantities or thick cuts of meat.

Allow the griller to pre-heat for approx. 2 minutes before sliding the tray into position.

Place the grill tray into the roasting pan and arrange food according to the function you have selected, either in the centre of the tray or spread across the full width of the tray. Position the tray at the correct grilling level and turn the thermostat control to MAX for best results.

As the temperature is set to MAX you may need to adjust your grilling shelf height to suit the desired cooking result. If the tray is too close to the element, the food will be exposed to the full effect of the element and may burn or create smoke.

RECIPES:

Welsh Rarebit

Ingredients	<i>250g cheddar cheese</i>
	<i>2 tblsp plain flour</i>
	<i>4 tblsp milk</i>
	<i>1 tsp worcestershire sauce</i>
	<i>1/2 tsp dry mustard</i>
	<i>Salt & pepper</i>
	<i>1 egg yolk</i>
	<i>30g butter</i>
	<i>8 slices bread</i>

SCALA OVEN

Method

Place cheese, flour (sifted), milk, worcestershire sauce, mustard and butter in microwave or melt on stove top. Stir until cheese is melted.

Add beaten egg yolk. Continue to stir until almost boiling, although do not allow boil. Remove from heat.

Toast bread and cut off crusts. Spread cheese mixture evenly over bread. Place on Shelf 1 under griller until golden brown. Serve hot.

Fish Provincial

Ingredients

500g fish fillets
Salt & pepper
1/3 cup lemon juice
1 clove garlic (crushed)
1/4 cup chopped parsley
470g can tomatoes
1/4 cup dry white wine

Method

Pre-heat grill on MAX for 2-3 minutes.
Season fish with salt and pepper. Place fish on grill tray.
Brush with lemon juice once during grilling.

Combine crushed garlic, parsley, undrained chopped tomatoes and wine in pan. Bring to the boil, reduce heat and simmer until thickened.

Pour sauce over fish to serve.

SCALA OVEN

Fan Grilling and Browning

Function 7: Fan grilling opens up new ways to prepare food by improving the appearance and flavour. Ideal for chicken, meat, fish and vegetables, as well as sauce-based dishes with cheese or crumbed toppings.

Arrange food on the grilling pan and place at the appropriate grilling level. Select Function 7 and turn the thermostat knob to the desired temperature and close the door of the oven. Pre-heat the grill for best results.

The fan works in conjunction with the top grilling element. The fan forces the heat into the food to cook it through, whilst the grill element browns the food from above. Even though the food is cooked throughout, you may wish to turn the food to brown the underside.

For sauce-based recipes or re-heating we recommend that you use the third shelf down and set the thermostat to 180°C. Cook until the crumb topping is brown or the sauce is just bubbling - approximately 20-30 minutes.

Fan grilling is faster than conventional grilling, so we suggest you reduce heat and time when you first begin using this method to avoid burning.

RECIPES:

Roast Leg of Lamb

Ingredients *2kg leg lamb*
 Pepper
 Cayenne pepper
 Celery
 Salt
 Dash of oregano
 6 garlic cloves

Sauce:
 120ml stock
 30ml white wine
 Pinch thyme, oregano
 10ml (2 tsp) cornflour

Method Pre-heat your oven to 170°. Rub seasoning in well. Insert cut slices of garlic into the lamb. Cook on Shelf 3 at 170°. Turn after 45 minutes. Continue to cook for a further 45 minutes for a medium cooked roast. You will need to modify the cooking time to suit your own taste for either a rare or well-done result.

To make the sauce, pour meat juice from roasting pan into a saucepan. Add stock, wine and seasoning and simmer for 5 minutes. Thicken with cornflour as required.

SCALA OVEN

Piquant Pork Chops

Ingredients *4 thick pork chops*
 1/2 clove of garlic
 Pepper, paprika
 Seasoning, salt
 2 onions (peeled and sliced)
 4 tblsp tomato puree
 3 whole tomatoes

Method Pre-heat the grill to 180°. Press garlic and salt together. Cover the base of a flat dish with onions. Spread tomato puree evenly over onions. Season chops with garlic, pepper, paprika and salt and arrange in the dish. Wash tomatoes, then cut into wedges and lay on top of the meat.

Grill for approx. 60 minutes on Shelf 3 at 180°.

.....

Cauliflower Parmigiana

Ingredients *1 large cauliflower, cut into generous flowerets*
 2 tblsp oil
 2 cups fresh breadcrumbs
 1/2 cup grated parmesan cheese
 3/4 cup diced or grated cheese - jalsberg or cheddar
 2 tblsp chopped parsley

Method Boil the cauliflower in 2 cups of lightly salted water until tender. Drain carefully in a colander. Heat oil and fry breadcrumbs.

Oil a shallow baking dish, sprinkle with a little grated parmesan cheese, arrange the flowerets in the dish and sprinkle with the diced or grated cheese, then the breadcrumbs mixed with remaining parmesan cheese.

Set fan grill at 180°, place dish on Shelf 2. Cook for 10-15 minutes or until the top is golden. Remove and sprinkle with chopped parsley. Serve hot.

SCALA OVEN

Grilling Chart

The following chart may assist you when grilling various foods:-

FAN GRILLING AND BROWNING GUIDE. Shelves are numbered from the top down.					
FOOD			SHELF	OVEN TEMP. C	APPROX. TIME
Bacon			1	MAX	5-6 mins
Beef	Roasts	Rare	3	180	20 mins per 500g
		Medium	3	160	30-35 mins per 500g
	Steaks	Rare	1	-	8-10 mins
		Medium	2	-	12-14 mins
Chicken	Whole		3	180	30 mins per 500g
	Pieces		2	190	15-20 mins
Fish	Fillets	Rolled	2	-	12 mins
		Thick	2	-	12 mins
	Whole		2,3	220	15-30 mins
Lamb	Roasts		3	160	35 mins per 500g
	Loin Rack		3	180	25 mins per 500g
	Chops	Medium rare	1	200	10-12 mins
		Medium	2	200	15mins
Pasta			3	160	20-30 mins
Pork	Roasts		3	180	30 mins per 500g
	Chops		2	200	15-20 mins
Sauce-based Recipes with Breadcrumb Toppings			3	180	20-30 mins
Sausages			2	-	10 mins
Sliced Vegetables			2,3	180-190	20-30 mins
Tomato Halves			2	-	5 mins

NORMAL GRILL CHART Shelves are numbered from the top down.					
FOOD			SHELF		COOKING TIME IN MINUTES
Bacon			1		4-6
Beef	Steaks	Rare	1		8-10
		Medium	2		15
		Well done	2		20
		Well done	2		10
	Rissoles	Well done	2		10
Vegetables			2		5-10
Fish	Fillets		1		5-8
	Cutlets		2		6-10
Fruit			1,2		5-10
Ham Steak		Well done	2		12-15
Lamb Chops		Well done	2		10

SCALA OVEN

Patisserie Setting

Function 8: This setting combines the bottom element with the fan which is ideal for cooking fine pastries, tarts and other foods which require crisp cooked bases. The heat is directed at the bottom of the food and the fan assists the heat to penetrate, cooking the interior without browning the top. As the bottom element is concealed, it is normal for the oven to take a few minutes more than the other fan functions to heat.

For best results, pre-heat the oven on Function 3 then turn to Function 8 when you are ready for baking.

RECIPE:

Custard Tart

Ingredients *Uncooked pastry flan*
 3 eggs
 2 cups milk
 1 tblsp sugar
 1 tsp vanilla essence
 Nutmeg

Method Pre-heat oven on Function 3 to 180°.
 Combine eggs, milk, sugar and vanilla essence and mix well.
 Pour mixture into uncooked pastry shell and sprinkle with nutmeg.
 Change Function setting to 8 and cook on Shelf 4 at 170 - 180°
 for 30-45 minutes.

All times and settings given are a guide only. Please experiment with your oven.

Food Types	Function	Normal Temp	Fan Forced Temp	Shelf#	Function	Time	Function	Time
Baked Products								
1 tray	3 or 4	170-180	160-170	2,3,4	3	15-25 min	4	10-20 min
ie. biscuits, etc 2-3 trays	4	170-180	160-170					
Casseroles								
Beef, Veal	3 or 4	170-180	160-170	3,4	3	2-3 hrs	4	2-2 1/2 hrs
Lamb, Mutton Pork	3 or 4	160-180	150-170	3,4	3	2-3 hrs	4	2-2 1/2 hrs
Poultry	3 or 4	170-180°	160-170°	3,4	3	1-2 hrs	4	1-1 3/4 hrs
Egg Recipes								
Baked Custards	3	180		3	3	20-30 min		
Souffles Large	3 or 4	180	160	3	3	40-55 min	4	40-50 min
Pavlova	3 or 4	150/100	140/90	3,4	3	2-2 1/2 hrs	4	2-2 1/4 hrs
Meringues	3 or 4	170-180°	160-170°	2,3	3	15-20 min	4	12-15 min
Fish								
Filets	3,4 or 7	180°	160°	2,3	3	15-30 min	4,7	15-25 min
Whole	3,4 or 7	180°	160°	2,3	3	25-50 min	4,7	20-45 min
Fruit								
Baked	3,4	200°	180-190°	2,3,4	3	50-60 min	4	45-55 min
Fruit Crumbles	3,4	180°	160-170°	2,3,4	3	20-40 min	4	20-30 min
Beef								
Roast	3 or 4	175-190°	160-180°	3,4	3	25-30 m/500g	4	20-25m/500g
Steaks Rare	6	MAX°		1,2	6	4-8 min		
Steaks: Med-Well Done	6 or 7	180°	160-180°	1,2	6	6-12 min	7	10-15 min
Rissoles	7		160-180°	1,2	7	6-12 min		

Food Types	Function	Normal Temp	Fan Forced Temp	Shelf#	Function	Time	Function	Time
Lamb								
Roast	3 or 4	170-190°	160-180°	3,4	3	25-30 m/500g	4	20-25 m/500g
Chops	6 or 7	180-200°	160-180°	2	6	12-18 min	7	10-15 min
Rissoles	7		160-180°	1,2	7		7	6-12 min
Pork								
Roast	3 or 7	170-190°	160-180°	3,4	3	30m/500g	7	30 m/500g
Chops / Steak	7		180-200°	2			7	15-20 min
Vegetables								
Baked	3,4	180-200°	170-190°	3,4	3	45-60 min	4	40-50 min
Roast	3,4	170-190°	160-180°	3,4	3	1-1 1/2 hrs	4	
Pasta Dishes								
	4		160-180°	3	4	20-25 min		
Pies & Pastry								
Short	4,8	200°	180°	2,3	4	20-25 min	8	30-40 min
Puff	4,8	230-250°	210-230°	2,3	4	10-15 min	8	15-25 min
Poultry								
Chicken	3,4	160-180°	160-170°	3,4	3	25-30 m/500g	4	25m/500g
Whole	7		160-180°	2			7	15-25min
Pieces								
Turkey								
Whole	3,4	160-180°	160-170°	3,4	3	25-30 m/500g	4	25m/500g
Reheating Cooked Foods								
	4		160-180°	3			4	
Sauce - Base Recipes with Breadcrumbs Toppings								
	4		160-175°	3			4	20-35min

SCALA OVEN

Free In-Home Demonstration

Please contact our Customer Services Office on 1-800-072-144 to arrange your free in-home demonstration.

Our trained Demonstrator will make an appointment to visit you in your home or to explain over the telephone how to confidently use and care for your oven.

Please note that we may not have a Kleenmaid Demonstrator in some regional areas. In these cases we will organise a step-by-step telephone demonstration to ensure you are able to achieve the best results from your oven.

A full explanation of the following will be provided during the demonstration:-

Removing the Oven Door

Removing the oven door allows easy access to the interior of the oven for cleaning. To do so:-

At either side of the door, the hinges (A) have two clips (B) which can be moved. Normally these remain flat against the hinges (A).

Step 1: Open the door fully, when it is lying flat, place the clips [(B) over part (C) of the hinge]. (You may need to gently press down on the centre of the door with one hand to assist with placement of the clips). The door is now ready to be removed.

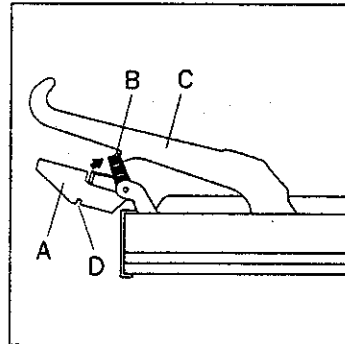

Step 2: Grip the door on either side and lift it outwards and upwards towards yourself. See the illustrations.

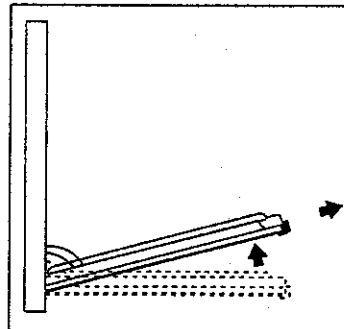

Step 3: To replace the door, insert the hinges completely into the oven hinge frame. Ensure that the notch (D) sits squarely into the oven hinge frame.

Step 4: Unclip the two clips (B) which hold the two hinges. (You **MUST** unclip the clips) The door is now in place.

Note: Attempting to close the door while the clip (B) is still attached to (C) will cause damage to the door hinges.

SCALA OVEN

Cleaning the Oven

To alleviate unnecessary odour and smoke during cooking it is important to clean your oven regularly.

It is best to deal promptly with spills. This can be most easily achieved with a moist sponge whilst the oven is still warm. (Take care not to burn yourself). If necessary a non-caustic oven cleaner may be used.

AVOID cleaning the external door glass and the stainless steel control panel when they are very hot.

However, for baked-on spills it may be necessary to use a creme cleanser and scraper.

Kleenmaid recommends you use non-abrasive MICA CLEANER for oven interiors, glass exteriors, stainless steel surface and ceramic cooktop glass. Ask your Demonstrator about this product.

To clean the oven's inner glass, see instructions under "Removing the door".

Drop Down Grilling Element

The removal of a single screw at the front of the upper grill element allows the grill to drop down to facilitate the cleaning of the oven ceiling. On completion of cleaning, simply replace the grill element and secure with the screw, finger-tight.

To avoid smoking, use a clean, damp cloth to regularly clean oil and fat splatters from the exposed drop down grilling element.

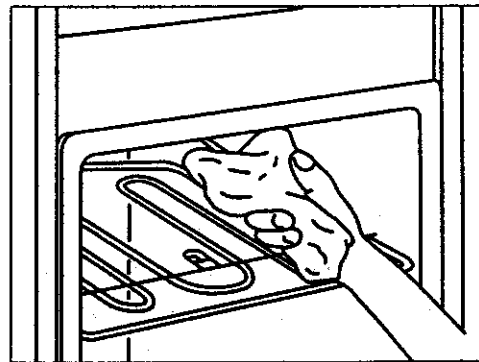
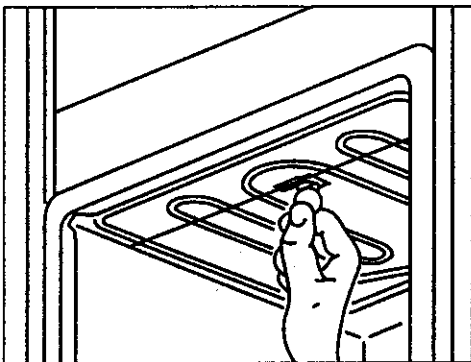

SCALA OVEN

*Changing the Oven Light Bulb**

- Step 1: Remove cover (A) by unscrewing in an anti-clockwise direction.
- Step 2: Replace bulb (15 W GES)
- Step 3: Replace cover (A) by screwing in a clockwise direction.

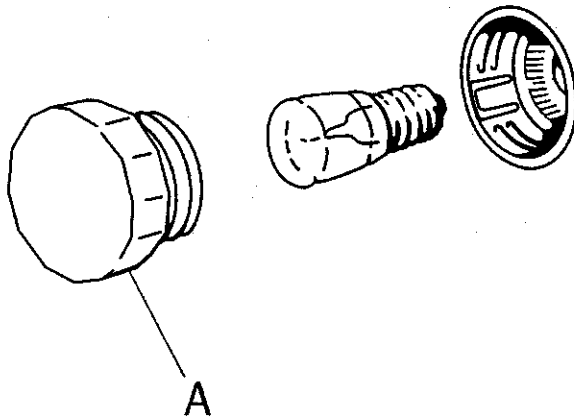

*Light bulbs are not covered by warranty.

Cleaning the Oven Glass

You now have easy access to the interior of the oven. To clean the door glass, use a coin or large screwdriver to loosen the screws. Wipe both sides of the inner, middle and outer glass. Wipe sealing gasket.

Don't forget to replace the rubber sealing gasket around the centre glass layer before replacing the glass. Ensure the narrow air gap lies between the inner and centre glass layers and the wider gap lies between the centre and outside glass layers.

Tighten each screw gradually, one then the other until firm. Do not overtighten.

SCALA OVEN

Domestic Warranty - Full Five Year Warranty

In addition to all statutory rights which you, the Consumer, have under all the relevant laws in respect of this appliance, during your first one year of ownership as the purchaser of the Kleenmaid washing machine, we guarantee that any fault caused by fault material or workmanship becoming apparent will be rectified free of charge for parts or labour provided that all service is performed during normal working hours by Kleenmaid or their designated Agent. Where the washing machine is installed outside the normal servicing area of the above, the Purchaser must pay the cost of transporting the appliance to and from the Agent or the Agent's traveling cost to and from the Purchaser's home.

Commercial Warranty - Trade Second Warranty

The warranty on all Trade Second Appliances is the same as the warranty supplied with new appliances, however, there are certain conditions that do not apply to Trade Seconds. Please contact National Customer Service on 1 800 072 144 for further details.

What These Warranties Do Not Cover

We are not responsible for any damage or malfunction unless caused by a defect in material or workmanship. This includes, but is not limited to, abuse, misuse, improper installation, and transportation damage. We are not responsible for any consequential damages resulting from any malfunction.

Warranty does not cover replacement of light globes.

Please complete your warranty card and post it to us.

To assist you when calling our Customer Service number to arrange a service call, please complete the following and have these details ready when you call.

Model No.* _____

Kleenmaid Store purchased from _____

Date of purchase ___/___/___

Date of installation ___/___/___

Should you require service, please call our National Customer Service Department on 1-800-072-144 (freecall).

** The oven Model No. is shown on the inside lower section of the oven door.*

Acknowledgment

With thanks to the Kleenmaid Demonstrators who provided the recipes included in this booklet.

MODELS TO-2A, TO-21A, TO-22A, TO-23A

Oven Cabinet Venting Details

Wall Mounted: (Single and One-and-a-Half Ovens). A rear venting duct should be formed 80-90mm deep and the width of the oven cavity. This allows any heated air in the oven cavity to escape upwards.

* Suitable vermin proofing to all ventilation openings.

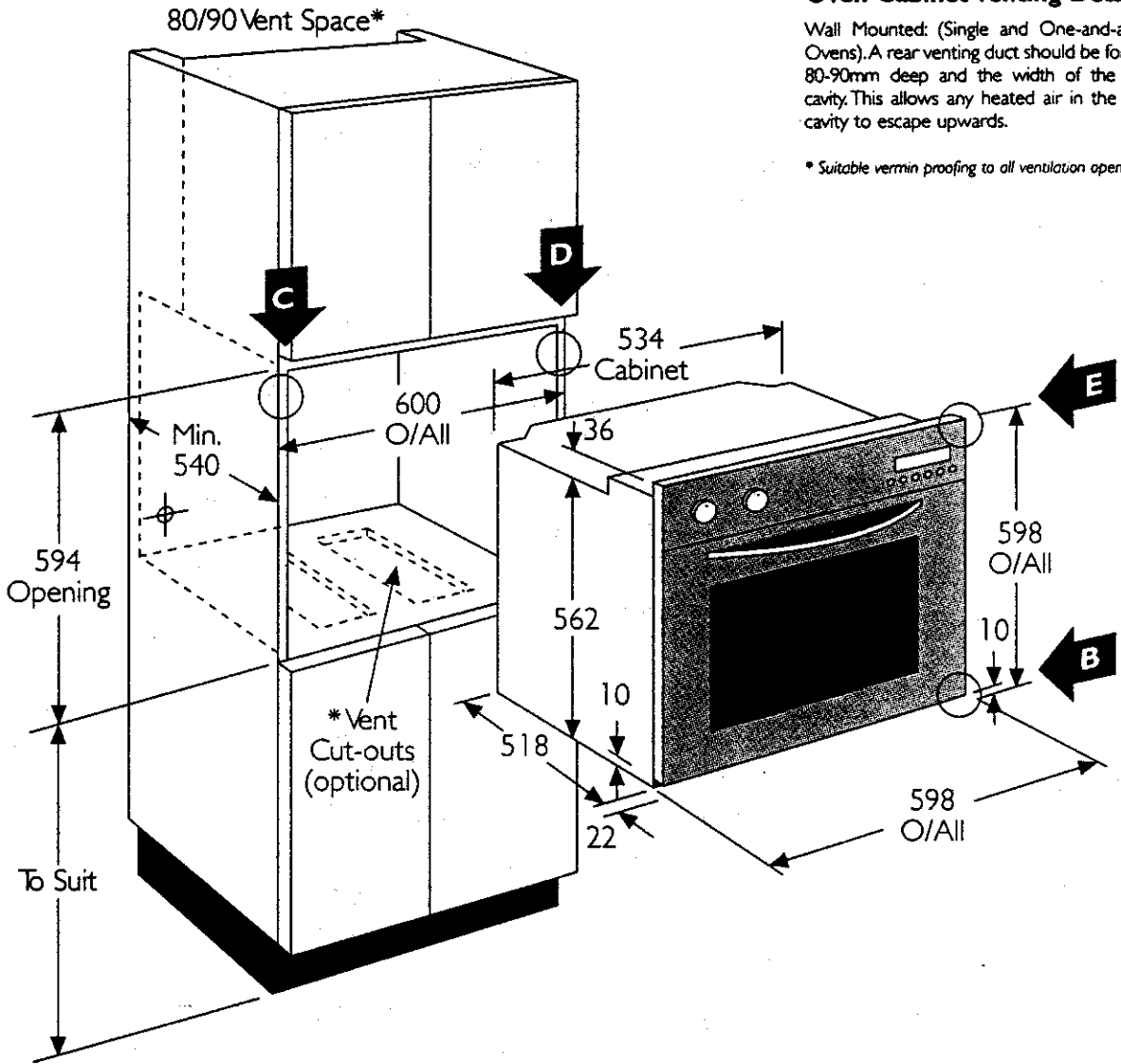

Model	Oven Capacity Litres	Electrical	Approval No.	Installation Method	Dimensions		
					H	W	D
TO-2A TO-21A TO-22A TO-23A	52	240V AC 11A 2640W	W2263	Flush	594	600 Overall	540
				Proud	Not Recommended		
N.B. Illustrations in this brochure show "Flush Mounted" dimensions.							

Kleenmaid's continuing commitment to quality products may mean a change in specifications without notice. Please contact 1800 072 144 before commencing cabinet construction.



FREE INFO HOTLINE: 1800 072 144

Metric Conversions

Weight

1 oz = 28 grams	4 oz = 113 grams	15 oz = 425 grams
2 oz = 56 grams	5 oz = 141 grams	16 oz = 453 grams
3 oz = 85 grams	10 oz = 283 grams	

Liquid Measures

1 pint = $\frac{1}{2}$ litre

Oven Temperatures*

Very Cool	225°F = 110°C
	250°F = 130°C
Cool	275°F = 140°C
	300°F = 150°C
Warm	325°F = 170°C
Moderate	350°F = 180°C
Moderate/Hot	375°F = 190°C
	400°F = 200°C
Hot	425°F = 220°C
	450°F = 230°C
Very Hot	475°F = 240°C

* Reduce by 10 - 20° for fan-forced functions.

NATIONAL CUSTOMER SERVICE PHONE: FREECALL 1-800-072-144

 **KLEENMAID**

THE WORLD'S BEST

Kleenmaid is a Registered Trading Name and is the property of Kleenmaid Pty. Limited. A.C.N. 001 905 808. Kitty Gee July '94