Owner's Manual

Model *TO5A*
 TO29A
 TO30A
Double oven
Grill / Fan-Forced

INDEX

Welcome to Kleenmaid and to the superior cooking efficiency of your new Scala oven.

Fan-forced oven - double	3
General Data	3
Control Panel	4
Use of minute timer	4
Using the oven functions	5
Installing the oven	6
FREE in-home demonstration	6
Changing the oven light bulb	7
Removing the oven door	7
Cleaning the oven	8
Self-cleaning panels	8
Baking Chart	9
Electrical connection	10
Warranty and service	11

FAN-FORCED OVEN - DOUBLE



Models from left to right:

TO5A
TO29A / T030A

GENERAL DATA

Dimensions of the oven	TO5A	TO29A TO30A
Height:	876 mm	898 mm
Width:	598 mm	598 mm
Depth:	540 mm	540 mm
(Overall depth is 542 mm, including 22 mm fascia trim)		

Cut-out cabinetry dimensions

Height:	876 mm	898 mm
Width:	554 mm	554 mm
Depth:	520 mm	52 mm

Electrical Data

240V, 50 Hz, 4800W

Approval Number W2263

Accessories supplied

1 x enamelled pan, 2 x racks, 1 x shallow drip pan, 1 baking tray, 1 x grill deflector

Cooking volume

Main Oven	52 litres
Griller	28 litres

CONTROL PANEL

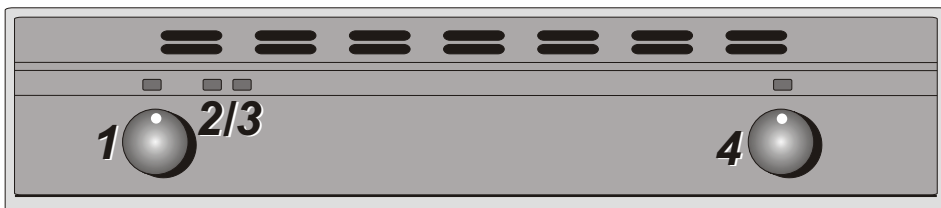

Provides various cooking options.

2. Yellow indicator light - indicates elements are energised. Will turn off when temperature is reached, then on again each time the thermostat indicates more heat is needed.

3. Red indicator light - indicates a function has been selected

4. Minute Minder -
Allows normal count down timing.

SELF-CLEANING PANELS

USE OF MINUTE MINDER

To use the minute minder turn the knob clockwise to the chosen position. A ringing buzzer will advise when the time has elapsed.

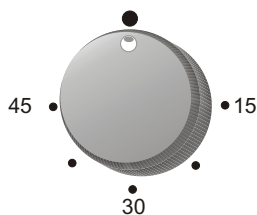

USING THE OVEN FUNCTIONS

Using the **OVEN FUNCTION SELECTOR KNOB**, the following functions are available:

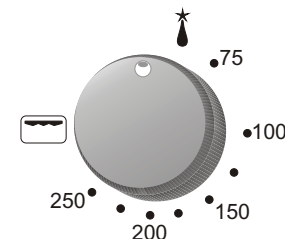

★ DEFROST: activates fan only and allows slow controlled defrosting.

FAN-FORCED COOKING: set thermostat knob between 75° C and 250° C. The fan-forced system allows you to cook foods on several shelves with even heat distribution throughout the oven.

Selected the temperature required on thermostat. When temperature is reached the yellow light will go out and then begin to alternate between "lit" and "unlit" as the temperature is controlled.

NOTE: The major advantage of fan-forced cooking, apart from even heat distribution, is that oven pre-heating is generally not required; pre-heating is needed only when cooking fine pastries. Another advantage of fan-forced cooking is that foods of different kinds may all be cooked together, without mixing flavours or aromas. Remember, however, use the fan-forced setting only when all the oven contents require the same cooking temperature.

For the most efficient cooking, meat should be placed directly on the roasting tray. It will not require turning and should be cooked at between 180° C and 190° C. - any higher temperature will cause burning, smoking and make the oven dirty. Extra time should be allowed for cooking where meat is placed in a covered pan. For superb flavour, cover the meat with thin strips of bacon or baste with lard and cook in the centre of the oven. If meat or poultry is large, lower the temperature by 10° C.

GRILLING: Use the variable Grill Control to set the grill function between 1 and 12. The highest power is obtained at 12.

INSTALLING THE OVEN

IMPORTANT: Connection to electrical mains must only be performed by a licensed electrical contractor. All care must be taken to ensure the installation is properly earthed and conforms to all local codes.

Refer to GENERAL DATA (page 3) for details of the particular cut-out and depth dimensions required for the model oven installed. Prepare the cut-out in the cabinet and ensure that side slide rails are available to allow the underside of the oven to be supported whilst allowing the unit to slide in.

Use the 4 screws provided to secure the front trim side rails to the cabinet front.

Scala ovens may be installed in any type of heat resistant cabinet (we suggest you speak to your cabinet maker for further information).

When installed as a wall unit, ensure that the upper-rear section of the cabinet has an 80-90 mm depth vent.

NOTE: Any vertical cupboard panels immediately beside the wall oven must be sealed completely to obtain the best result from your oven.

IMPORTANT: So that your Scala oven maintains its efficient sealing capacity for the life of the appliance, **NEVER USE THE DOOR AS A LEVER** (especially when the oven is being installed into its recess). Similarly, **undue pressure must never be placed on the oven door when it is open.**

FREE IN-HOME DEMONSTRATION

Please contact our Customer Call Centre on 1 800 072 144 to arrange for your FREE In-Home Demonstration.

Our trained Demonstrator will make an appointment to visit you in your home and explain how to confidently use and care for your appliance.

Please note that we may not have a Kleenmaid Demonstrator in some regional areas. In this case we will organise a step-by-step telephone demonstration to ensure you are able to achieve the best result from your appliance.

CHANGING THE OVEN LIGHT BULB

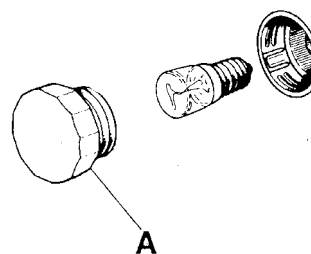

1. Remove cover (A) by unscrewing in an anticlockwise direction.

2. Replace bulb (15W SES) Available through Kleenmaid Stores and Customer Call Centre on 1 800 072 144.

3. Remount cover (A)

REMOVING THE OVEN DOOR

Removing the door allows easy access to the interior of the oven for cleaning. To do so:-

1. (FIG 1) At either side of the door, the hinges (A) have two clips (B) which can be moved. Normally these remain flat against hinges (A). Open the door fully and hook the clips (B) to the part (C) of the hinges. The door assembly can now be removed.

2. Lift the door towards the outside (FIG 2). Two movements are required, up and towards yourself, gripping the door near each hinge.

3. To replace the door, insert the hinges completely into the grooves.

4. Unclip the two clips (B) which hold the two hinges - **THIS IS IMPORTANT!** The door is now in place.

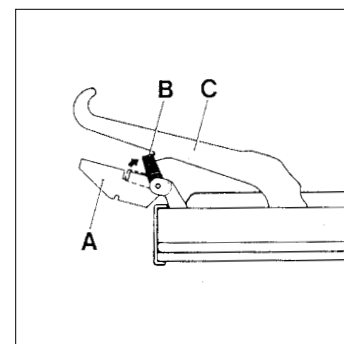

FIG 1

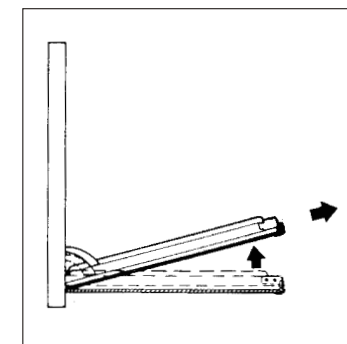

FIG 2

CLEANING THE OVEN

To alleviate unnecessary odour and smoke during cooking it is important to clean your oven regularly. It is best to deal promptly with stains caused by spills during cooking. This can be most easily achieved with a moist sponge whilst the oven is STILL WARM. (Take care not to burn yourself).

Use warm water and liquid detergent to clean the enamel and decorative control panel, door, etc. Dry with a soft cloth. NEVER use abrasive powder or acid/chlorine based cleaners.

Always avoid cleaning the glass until COLD. The inner glass can be easily removed when necessary by unscrewing the 2 locating screws with a coin. Be careful to re-position the door gasket accurately when re-assembling after cleaning.

SELF - CLEANING PANELS

Self Cleaning Panels (Part Number SPA 2) may be purchased as an optional extra for the fan oven cavity. They are attached to the sides by removing the rack guide assemblies and placing the self cleaning panels against the oven side walls over the pins. Ensure that the ROUGH side is facing out. These liners are self cleaning during the oven's heat cycle. If residue remains on them after cooking, empty the oven of food and turn the thermostat to MAX; 15-20 minutes should be adequate to clean the panels using this method.

How the Self Cleaning Panels Work

The self-cleaning oven panels go through a special enamelling process which ultimately creates a rough surface (this is the side which should face outward in the oven).

Because of the structure of the surface, it is extremely porous and attracts oxygen. When the stain hits this surface it immediately spreads outward. In this way, immediate oxidation of the stain occurs and it ultimately disappears while the oven is in general use at standard cooking temperatures. The self cleaning panels are designed to cope with fatty stains very efficiently. For stains on the bottom of the oven, the usual causes are sugar or starch overflows.

BEWARE: Never use silicone films (polishes or cleaners) on self-cleaning panels - they will be rendered useless. Similarly, NEVER try to wash with detergent or use abrasive cleaners on the panels.

BAKING CHART

The below are recommendations only. Please refer to your own recipe for personal taste.

*Shelf positions are numbered from the top, down.

		NORMAL BAKE SHELF*	TEMP ° C	Time
BAKED PRODUCTS				
Bread	loaves	3	210-220	30-45mins
	Rolls	3	200-210	15-20mins
Cakes	butter	3	180	45-60mins
	Patty	3	180	15-20mins
	Rich fruit	3,4	140-150	1.5-2hrs
	Sponge	3	180-190	15-25mins
Meringues		3	100-110	1.25-1.5hrs
Muffins		3	200-220	15-20mins
Pastry	short	2,3	200	10-15mins
	Flaky	2,3	230	10-20mins
	Puff	3	230-250	10-20mins
	Choux	3	230/190-	40-60mins
CASSEROLES				
	Beef, Veal	3,4	160	2.25-3hrs
	Lamb, Mutton, Pork	3,4	160	1.75-2.25hrs
	Poultry	3,4	170	1-1.25hrs
DESSERTS				
	Baked cake type	3	180-200	20-30mins
	Baked custard	3	180	35-45mins
	Baked fruit	2,3	200	50-60mins
	Fruit crumbless	2,3	180	20-40mins
	Meringue toppings	3	180-200	15-20mins
	Pavlova	3	150/100	2-2.5hrs
FISH				
	whole	2,3	180	25-50mins
	Fillets	2,3	180	15-30mins
POULTRY				
	Chicken pieces	2,3	180	30-45mins
	Whole	3	180	1-1.15mins
SOUFFLES				
	Large	3	180	45-55mins
	Individual	3	180	35-50mins
VEGETABLES				
	Baked potatoes	2,3,4	200	35-45mins
	Oven cooked rice	2,3	180	40mins
	Roast	2,3,4	180	35-45 mins

ELECTRICAL CONNECTION

Any electrical wiring must be carried out in compliance with the local electrical board regulations by a qualified electrician.

WARNING: ALL APPLIANCES MUST BE EARTHED

Kleenmaid cannot accept responsibility for any damage to persons or property arising from faulty connection or non connection to earth.

Before connection or installing this appliance, the electrical supply must be switched off.

SETTLING THE OVEN

When you first use your oven, the oven will need to “settle”. That is, it needs to burn off production residues and dust. The metal used in the oven will also expand slightly when first used. You will experience some crackling and a strong smell. This is perfectly normal and we advise you anticipate this “settling” prior to use.

TOP GRILL SETTLING INSTRUCTIONS

Using an empty oven, place grill thermostat on position number 6 for 5 minutes.

MAIN OVEN SETTLING INSTRUCTIONS

Using an empty oven, select Function number 4 and set a temperature of 250 degrees, allow to “settle” for ½ hour.

Turn to Function number 3 and heat for a further ½ hour.

WARRANTY AND SERVICE

DOMESTIC WARRANTY - Full Five Year Warranty

In addition to all statutory rights which you, the Consumer, have under all the relevant laws in respect of this appliance, during the first five years of ownership as the purchaser of this Kleenmaid appliance, we guarantee that any fault caused by faulty material or workmanship becoming apparent, will be rectified free of charge for parts and labour, provided that all service is performed during normal working hours by Kleenmaid or their designated Agents. Where the appliance is installed outside the normal servicing area of the above, the Purchaser must pay for the cost of transporting the appliance to and from the Agent or the Agent’s travelling cost to and from the Purchaser’s home.

COMMERCIAL WARRANTY - One Year Warranty

When this appliance is installed in a commercial application, you, the Consumer, have under all the relevant laws in respect of this appliance, during the first year of ownership as the original purchaser of this Kleenmaid appliance, we guarantee that any fault caused by faulty material or workmanship becoming apparent, will be rectified free of charge for parts and labour, provided that all service is performed during normal working hours by Kleenmaid or their designated Agents. Where the appliance is installed outside the normal servicing area of the above, the Purchaser must pay for the cost of transporting the appliance to and from the Agent or the Agent’s travelling cost to and from the Purchaser’s home.

WHAT THIS WARRANTY DOES NOT COVER

We are not responsible for any damage or malfunction unless by a defect in material or workmanship. This includes and is not limited to abuse, misuse, improper installation and transporting damage. Kleenmaid will not be responsible for any consequential damages resulting from any malfunction.

WARRANTY DOES NOT COVER REPLACEMENT OF LIGHT GLOBES OR GLASS BREAKAGE

In case of fractured glass do not use your appliance.

WARRANTY REGISTRATION

Please fill in the enclosed warranty card and post it to us or phone our our Customer Call Centre.

SERVICE AND ASSISTANCE

To assist you when calling our Customer Call Centre number to arrange a service call, please complete the following and have these details ready when you call.

Model: _____

Kleenmaid Store purchased from: _____

Date of purchase: _____

Date of installation: _____

**KLEENMAID CUSTOMER CALL CENTRE
CONTACT NUMBER
1 800 072 144**