

SCALA OVEN

Model TO6A TO31 TO32 TO33
TO31A TO32A TO33A

Owner's Manual

 **KLEENMAID**
THE WORLD'S BEST

SCALA OVEN

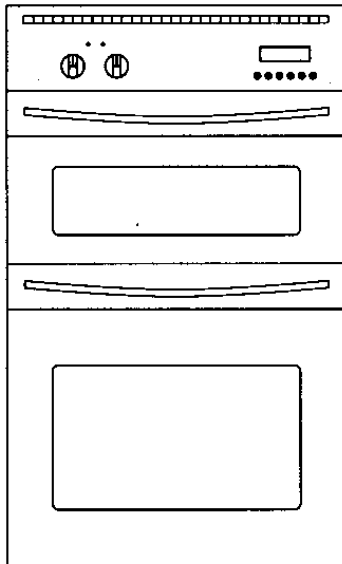

Model Description

- TO - 6A Stainless Steel One-and-a-Half Oven
- TO - 31A White glass front One-and-a-Half Oven
- TO - 32A Black glass front One-and-a-Half Oven
- TO - 33A Mirror glass front One-and-a-Half Oven

Installation

IMPORTANT: Connection to electrical mains must only be performed by a licensed electrical contractor. All care must be taken to ensure the installation is properly earthed and conforms to all local codes.

Use the 6 screws and washers provided to secure the front trim side rails to the cabinet front to ensure safe usage. Take extra care when screwing through the enamelled frame not to overtighten causing enamel damage.

Kleenmaid ovens may be installed in any type of heat resistant cabinet (eg. timber finished in plastic laminate, timber, metal, brickwork etc).

When installed as a wall unit, ensure that the upper-rear section of the cabinet has a minimum 20mm depth vent.

Note: Any vertical cupboard panels immediately beside the wall oven must be sealed completely to obtain the best results from your oven.

DO NOT use the door as a lever to assist with installation into its recess. Undue pressure must never be placed on the oven door when it is open.

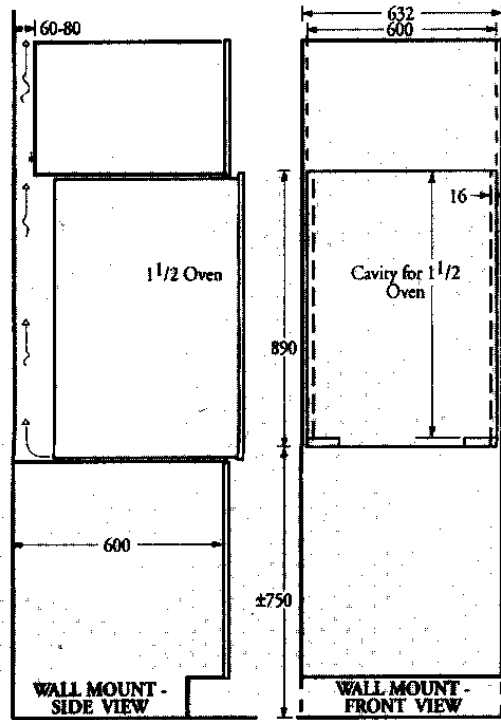
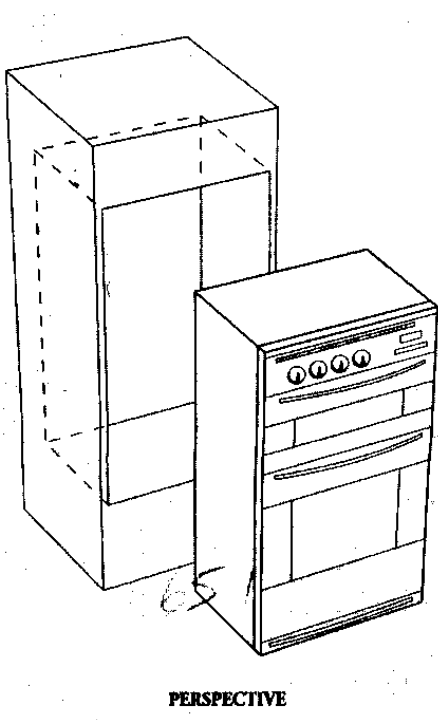

KLEENMAID SCALA OVENS - FLUSH FITTING DETAIL

Cabinet details: For a "flush mounted" appearance, apply the following cabinet construction details for Wall-Mounted (column) applications.

Cavity Construction: The oven cabinet should be constructed so that it is a fully sealed box surrounding the oven at the top, bottom and sides, with a venting cavity at the rear.

Cabinet Venting: When a Kleenmaid Scala Oven is installed into a Wall-Mount situation (left), a rear venting duct must be formed, 60-80 mm deep and the full oven width (far left). Take care not to obstruct the cooling grills at the top and bottom of the oven - these are essential to allow airflow to cool the exterior of the oven.

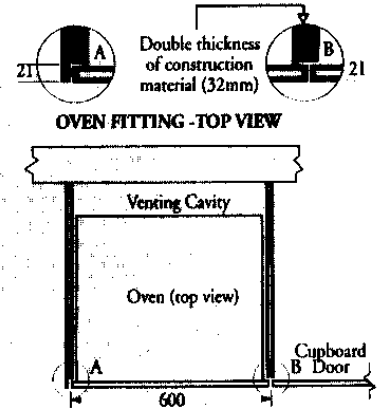

SCALA OVEN

Inclusions

- 1 x shallow enamelled baking pan
- 1 x enamelled roasting/grilling pan with grilling rack
- 3 x enamelled baking trays
- 3 x oven racks
- 1 x grilling deflector

Control Panel

1. **Multi-function selector dial** - for the selection of various cooking options in the main oven.
2. **Yellow indicator light** - this light indicates when a cooking function has been selected.
3. **Red indicator light** - this light indicates when the oven heating elements are energised. It will turn off when the desired temperature is reached, then on again each time the thermostat indicates more heat is required.
4. **Thermostat** - controls the cooking temperature.
5. **Half Oven selector dial** - for the selection of various cooking options in the half oven.
6. **Variable Grill temperature selector** - for the selection of grill heat intensity.
7. **Electronic Control Clock** - provides various timing functions from minute-minder to fully automatic cooking.

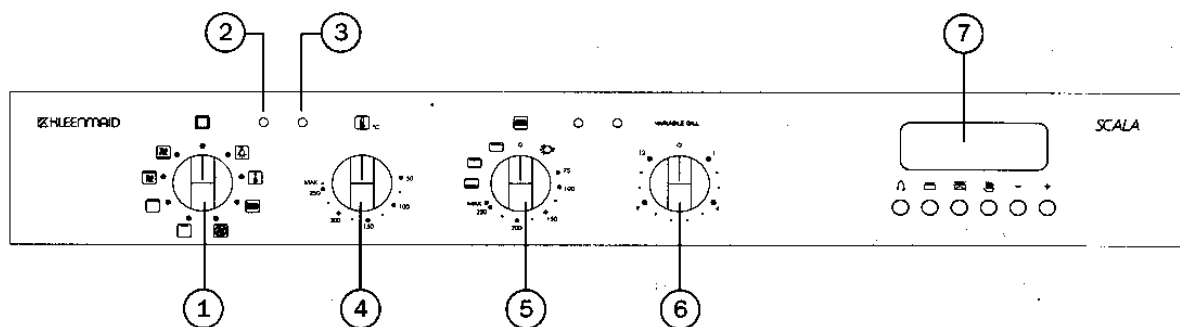







Oven Capacity

- | | |
|---------------------|----------|
| Half Oven | 28 litre |
| Multi-function Oven | 52 litre |



SCALA OVEN

Kleenmaid Scala Multi-Function Oven Function Selections

(Model Nos. TO - 6A, TO - 31A, TO - 32A, TO - 33A)

1.  **Light** - The light illuminates the oven during normal cooking modes, and assists you when cleaning the oven.
2.  **Defrost** - This function activates the fan only, (no heat is used) to allow controlled and hygienic defrosting.
3.  **Conventional Cooking** - Normal or traditional cooking function using the top and bottom elements. When using this function set the thermostat between 50 - 250°C. When the desired temperature is reached the red light will go out and then alternate between lit and unlit as the temperature is controlled.
4.  **Fan-forced Cooking** - This selection is best for multi-level cooking as the heat generated by the central element is circulated around the oven, creating an even heat environment. You will need to set the thermostat dial between 50 - 250°C for this function.
5.  **Centre Griller** - For best results set the thermostat to MAX. (The door may remain closed or completely open. If open the grilling deflector must be installed).
6.  **Large Griller** - For best results set the thermostat to MAX (The door may remain closed or completely open. If open the grilling deflector must be installed).

Note: The grill deflector will become hot with use, do not remove until cool.

7.  **Fan Griller** - This function combines the grill element with fan assistance and is used in conjunction with the thermostat. The oven door must remain CLOSED during cooking. The thermostat dial should be set between 50 - 250° for this function.
8.  **Fan-assisted Baking or Patisserie Setting** - Combines the concealed bottom element with fan assistance and is used in conjunction with the thermostat. The oven door must remain CLOSED during cooking.

SCALA OVEN



Half Oven Features:

9.  **Half Oven Function Selector** - provides combined thermostatic control for the half oven for conventional baking, maximum heat from the bottom element, or maximum heat from the upper element and Variable Grill selector.

The half oven used as a conventional oven is ideal for cooking biscuits, cakes, scones, roasting vegetables and preparing small quantities of food.

The half oven has been designed for cooking in proportion to its capacity and size and not as a replacement for the larger oven.

Cooking large amounts of food or roasting meat in this oven is not recommended. For best results use the multi-function oven.

10.  **Bottom Element Only** - allows full power from the bottom element.
11.  **Top Element Only** - allows full power from the top element.
12.  **Variable Grill temperature selector** - to be used in conjunction with the variable grill option on the combined thermostatic control knob for grilling. When grilling in the half oven the door may remain completely open or closed. If open, the grilling deflector must be installed.

SCALA OVEN

Advanced Oven Features

Cavity Cooling

The Kleenmaid Scala oven has an advanced cavity cooling system. A cylindrical fan is mounted on the rear outside frame of the oven. This fan assists the movement of air through the oven cavity keeping it cool. In addition to reducing the temperature in the oven cavity, the air is blown out through vents in the oven door handle which keeps the door handle perfectly cooled.

The cooling fan is activated when the oven light or any cooking function is selected and will continue to operate for ten minutes after all oven functions have been turned off. After this time the cooling fan will turn off automatically.

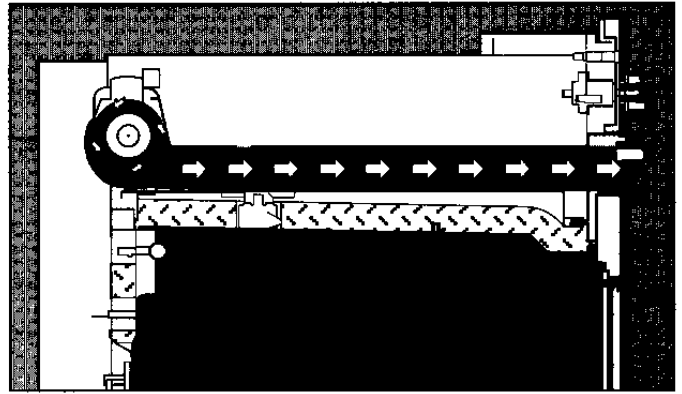

Triple Reflective Door Glazing

The Kleenmaid Scala has two levels of removable door glass. The two inner layers are removable and are made of a reflective glass which, in effect, reflects heat back into the oven and results in a significant reduction in the outside door surface temperature.

The glass is easily removed for cleaning. Use a 10¢ coin to loosen the screws, then remove each layer to clean. When replacing the glass ensure that the rubber gasket is placed around the centre glass layer so that the narrow air gap lies between the inner and centre glass. Do not overtighten screws when replacing the glass.

Wipe Clean Enamel

The baking trays and grill pans supplied with your oven are finished in the soft-grey super tough "wipe clean" enamel.

This enamel is less porous than conventional, so that food does not adhere as easily. Simply wipe clean with a soapy cloth or creme cleanser when cooking is finished. For baked on residue, use a scraper.

Drop Down Grill Element

The removal of a single screw at the front of the upper grill element allows the element to drop down so that cleaning the ceiling of the oven is made easy. On completion of cleaning, simply replace the grill element and secure with the screw, finger-tight.

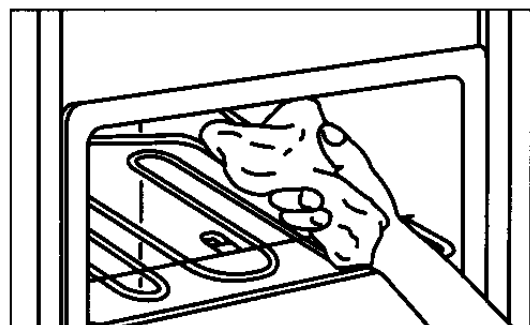
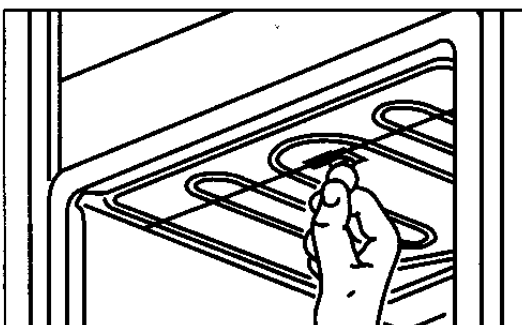

SCALA OVEN







The Electronic Timer

Note: Automatic cooking functions are possible using the electronic programmer.

The electronic timing control on your Scala oven provides more options than simple manual cooking i.e.





- Countdown timer for precise timing needs;
- Normal manual cooking
- Semi-Automatic. “Start Now - Stop Later”.
- Fully Automatic. “Start Later - Stop Later”.

The 24 hour clock allows you to set your automatic cooking options up to 24 hours in advance

1.  Countdown Timer and Alarm Bell Button
2.  Cooking Duration Button
3.  Finish Cooking Button
4.  Manual Operation Button
5.  Minus Time Button
6.  Plus Time Button

Setting the Time on the 24 Hour Clock

The clock will require setting when you first turn on the power (or following a power failure).

1. The AUTO symbol and the time 0:00 will flash;
2. Hold down the  button and  button simultaneously whilst using the “+” button to set the time of day. The time will advance slowly, then speed up. (If you over-shoot the desired time, use the “-” button). Once the desired time has been reached, release all of the buttons (the time you have set will disappear for a moment and then reappear with the AUTO symbol flashing beside it).
3. Press the  button to set the oven for manual cooking. The AUTO sign will disappear and the  symbol will appear in the middle of the time displayed.

THE OVEN IS NOW READY FOR USE AND TO ACCEPT THE DESIRED COOKING FUNCTIONS.

When you first use your oven, the oven will need to “settle”. That is, it needs to burn off production residues and dust. The metal used in the oven will also expand slightly when first used. You will experience some crackling and a strong smell. This is perfectly normal and we advise you anticipate this “settling” prior to use. Using an empty oven, select Function 4 and set a temperature of 250°, allow the oven to “settle” for ½ hour, turn to Function 3 and heat for a further ½ hour.

SCALA OVEN

Using the Countdown Timer

The timer can be set for any time up to 24 hours and will count down to zero. When it reaches zero a high-pitched alarm will sound. To set the Countdown Timer:

1. Depress the  button and release to show 0:00. Using “+” button advance the timer to the desired time.

2. Once the Countdown timer is set, the normal time of day will return to the display within 4 seconds.

If you wish to check how much time remains on the Countdown, simply depress the  for a moment. The remaining time will be displayed. After 4 seconds the normal time will return to the display.

3. To silence the alarm press the  button.

Manual Cooking

Once the time of day is set the  symbol will be displayed. The oven is now in manual operation mode ready for you to select the desired cooking function and temperature.



SCALA OVEN

Automatic Cooking Modes

Note: We suggest that the desired temperature and cooking function be set prior to the programming of any AUTO function.

Semi Automatic (Start Now - Stop Later):



A) Based on setting the duration

1. Set the function and temperature to the desired position.
2. Let's say you wish to cook for 45 minutes. Press and release the  button. For 4 seconds the 0:00 symbol will be displayed. During this time you need to set the duration cooking time of 45 minutes by pressing the "+" button (use the "-" button should you over-shoot the required time). Release and the display will return to the normal time of day. The AUTO symbol will also appear indicating that you have set the automatic cooking function.
3. The oven will operate for 45 minutes only, turn off automatically and the alarm will sound. The AUTO symbol will flash and the  symbol will disappear. The alarm will turn off soon after. To silence the alarm immediately, press any button except "+" or "-".
4. When you press the  button, the oven will return to normal cooking mode.

If further cooking is required, either leave on manual or repeat the above setting sequence.

Note: If you have not turned the function and thermostat settings off your oven will now continue to operate manually. The AUTO symbol will disappear and the  symbol will reappear.

B) Based on setting a cook stop time



1. Set the function and thermostat control to the desired position.
2. Let's say you commence cooking and decide you would like the oven to turn off at 6.00pm. Press and release the  button; the display will show no change. Press the "+" button within 4 seconds and advance to the desired completion time of 6.00pm, ie 18:00 on the 24 hour clock. The AUTO symbol will be illuminated.
3. The oven will continue to cook until 18:00 (6.00pm) and then switch off. The AUTO symbol will flash and the alarm will sound. Silence the alarm by pressing any of the buttons except "+" or "-".
4. Press the  button to return to manual cooking.

Note: If you have not turned the function and thermostat settings off your oven will now continue to operate manually. The AUTO symbol will disappear and the  symbol will reappear.

SCALA OVEN

Fully Automatic - (Start Later - Stop Later)

Your Scala oven may be programmed to start, cook for the desired time and turn off automatically. This function is particularly useful in the preparation of the evening meal, should you be out during the day, it will be ready on your return home. For example if your cooking time is 45 minutes and you want the cooking to finish at 6pm.

1. Press the  to set the cooking duration time for say 45 minutes using the “+” or “-” buttons. Release and the display will return to the normal time of day.
2. Next, press the  time and set at, 6.00pm (18:00). Release and the display will return to the normal time of day. The AUTO symbol will be displayed.



Using the above settings, the oven is now programmed automatically to commence cooking 45 minutes prior to 6.00pm then automatically turn off.

When cooking is complete, the AUTO symbol will flash and the alarm will sound. You may silence the alarm by pressing any button except “+” or “-”.

3. Press the  button to return to manual cooking. Note: Don't forget to turn off the cooking function and thermostat if cooking is complete as pressing the button will result in the oven continuing to operate manually.

Cancelling Automatic Settings

To cancel a programme:

- Step 1: Press the  button, and scroll back to 0:00 using the “+” or “-” button. The AUTO symbol will begin to flash on the display.
- Step 2: Press the  button to return to manual cooking.

SCALA OVEN

Multi-Function Oven Settings

Defrost

Function 2: The defrost setting allows natural thawing for delicate foods such as fine pastries, desserts, bacon slices and seafood. Rather than leaving them on a benchtop they may be defrosted in the closed hygienic environment of the oven.

DEFROST SUGGESTIONS:

This function is ideal for defrosting frozen meats and other freezer items, and particularly those items which require gentle defrosting such as:-

- Sara Lee desserts
- Bacon
- Fish fillets
- Bread
- Cakes, scones, etc

SCALA OVEN

Fan-Forced Baking

Function 4: Scala's fan-forced, central element cooking requires slightly different techniques and timing than normal cooking. The fan draws the air in and over the central element which is positioned around the fan and then circulates it back around the oven cavity. The even distribution of heat allows foods to rise and cook simultaneously regardless of shelf level. Lower cooking temperatures and in some cases less cooking time is another advantage of this feature.

Turn the Function Selector to Position 4 and turn the thermostat to the desired temperature. Pre-heating takes much less time than a normal bake oven.

Note: When cooking meats, for best results always pre-heat the oven to ensure the meat surface is sealed to lock-in juices for a moist and tender result.

Fan-forced cooking is ideal for multi-level cooking eg. patty cakes. Another advantage of fan-forced cooking is that different types of foods may be cooked simultaneously without mixing the aromas or flavours. When using the oven in this way, ensure that all the foods require the same cooking temperature and check the finish times of each dish for best results.

Please note that fan-forced cooking is faster than conventional methods, so take care not to burn your food when you first start using this method.

SCALA OVEN

Roast by Time and Weight

APPROXIMATE ROASTING TIMES				
MEAT		TEMPERATURE °C	MINUTES PER 800g	INTERNAL TEMPERATURE °C
Beef	Rare	160	25-30	60-65
	Medium	160	30-40	73-75
	Well done	160	40-45	78-80
Veal	Well done	160	35-40	78-80
Mutton		160	35-40	82
Hogget Lamb	Fillets	160	25-30	79-80

RECOMMENDED TEMPERATURE °C												
Fan-Forced	130	140	150	160	160	170	180	190	200	210	220	230
Normal Bake	140	150	160	170	180	190	200	210	220	230	240	250

SCALA OVEN

Grilling

Functions 5 & 6: During grilling the door may remain closed or completely open. If open, the grilling deflector must be installed. Place the deflector with the front edge angled upwards.

Important: DO NOT REST THE OVEN DOOR AGAINST THE DEFLECTOR.

Functions 5 & 6 offer the traditional grilling method necessary to achieve proper browning without overcooking the interior of the foods.

Position 5 activates the centre section of the upper grill element only, which is ideal for browning smaller portions or thinner cuts of meat.

Position 6 activates the entire upper element for the grilling of large quantities or thick cuts of meat.

Allow the griller to pre-heat for approx. 2 minutes before sliding the tray into position.

Place the grill tray into the roasting pan and arrange food according to the function you have selected, either in the centre of the tray or spread across the full width of the tray. Position the tray at the correct grilling level and turn the thermostat control to MAX for best results.

As the temperature is set to MAX you may need to adjust your grilling shelf height to suit the desired cooking result. If the tray is too close to the element, the food will be exposed to the full effect of the element and may burn or create smoke.

SCALA OVEN

Fan Grilling and Browning

Function 7: Fan grilling opens up new ways to prepare food by improving the appearance and flavour. Ideal for chicken, meat, fish and vegetables, as well as sauce-based dishes with cheese or crumbed toppings.

Arrange food on the grilling pan and place at the appropriate grilling level. Select Function 7 and turn the thermostat knob to the desired temperature and close the door of the oven. Pre-heat the grill for best results.

The fan works in conjunction with the top grilling element. The fan forces the heat into the food to cook it through, whilst the grill element browns the food from above. Even though the food is cooked throughout, you may wish to turn the food to brown the underside.

For sauce-based recipes or re-heating we recommend that you use the third shelf down and set the thermostat to 180°C. Cook until the crumb topping is brown or the sauce is just bubbling - approximately 20-30 minutes.

Fan grilling is faster than conventional grilling, so we suggest you reduce heat and time when you first begin using this method to avoid burning.

SCALA OVEN

Patisserie Setting

Function 8: This setting combines the bottom element with the fan which is ideal for cooking fine pastries, tarts and other foods which require crisp cooked bases.

The heat is directed at the bottom of the food and the fan assists the heat to penetrate, cooking the interior without browning the top. As the bottom element is concealed, it is normal for the oven to take a few minutes more than the other fan functions to heat.

For best results, pre-heat the oven on Function 3 then turn to Function 8 when you are ready for baking.

SCALA OVEN

Half Oven Functions:

Conventional Cooking:

The 28 litre half oven is a regular conventional oven which is thermostatically controlled. This oven is ideal for cooking small quantities of foods eg. scones, biscuits, cakes, roasting vegetables or cooking small cuts of meat. Pre-heat for best results.

The half oven has been designed for cooking in proportion to its capacity and size, not as a replacement for the larger oven. Use the multi-function oven for cooking large amounts of food or roasting meat.

SUGGESTION: Also ideal if used as a salamander to warm plates or keep food warm prior to serving.

Full-Power Bottom Element:

This function provides full power 250°C heat directed from the bottom element. This setting is ideal for fast, very hot cooking as required for cooking pizzas. For best results, pre-heat on conventional setting and switch to full-power bottom element when required.

Full-Power Upper Element:

This function provides full power 250°C heat directed from the upper outer element which is ideal for quick browning of foods.

SUGGESTION: Ideal for browning meringue or cheese topping.

SCALA OVEN

Variable Grill

The Variable Grill function enables the variation of heat through the inner top element enabling precise control of grilling temperature.

1 indicates a low heat and 12 indicates high.

The door may remain closed or completely open. If open the grill deflector must be installed.

SUGGESTIONS: Ideal for: Steaks
Chops
Fish fillets
Chicken pieces
Grilled tomatoes

SCALA OVEN

Free In-Home Demonstration

Please contact our Customer Services Office on 1-800-072-144 to arrange your free in-home demonstration.

Our trained Demonstrator will make an appointment to visit you in your home to show you how to confidently use and care for your oven.

Please note that we may not have a Kleenmaid Demonstrator in some regional areas. In these cases we will organise a step-by-step telephone demonstration to ensure you are able to achieve the best results from your oven.

A full explanation of the following will be provided during the demonstration:-

Removing the Oven Door

Removing the oven door allows easy access to the interior of the oven for cleaning. To do so:-

At either side of the door, the hinges (A) have two clips (B) which can be moved. Normally these remain flat against the hinges (A).

Step 1: Open the door fully, when it is lying flat, place the clips [(B) over part (C) of the hinge]. (You may need to gently press down on the centre of the door with one hand to assist with placement of the clips). The door is now ready to be removed.

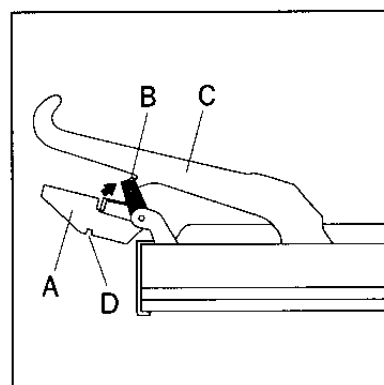

Step 2: Grip the door on either side and lift it outwards and upwards towards yourself. See the illustrations.

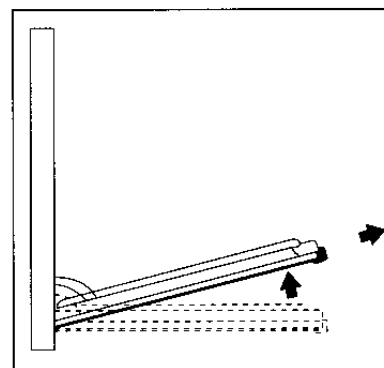

Step 3: To replace the door, insert the hinges completely into the oven hinge frame. Ensure that the notch (D) sits squarely into the oven hinge frame.

Step 4: Unclip the two clips (B) which hold the two hinges. (You MUST unclip the clips) The door is now in place.

Note: Attempting to close the door while the clip (B) is still attached to (C) will cause damage to the door hinges.

SCALA OVEN

Cleaning the Oven

To alleviate unnecessary odour and smoke during cooking it is important to clean your oven regularly.

It is best to deal promptly with spills. This can be most easily achieved with a moist sponge whilst the oven is still warm. (Take care not to burn yourself).

AVOID cleaning the external door glass when it is very hot.

However, for baked-on spills it may be necessary to use a creme cleanser and scraper.

Kleenmaid recommends you use non-abrasive MICA CLEANER for oven interiors, glass exteriors, stainless steel surface and ceramic cooktop glass. Ask your Demonstrator about this product.

Drop Down Grilling Element

The removal of a single screw at the front of the upper grill element allows the grill to drop down to facilitate the cleaning of the oven ceiling. On completion of cleaning, simply replace the grill element and secure with the screw, finger-tight.

To avoid smoking, use a clean, damp cloth to regularly clean oil and fat splatters from the exposed drop down grilling element.

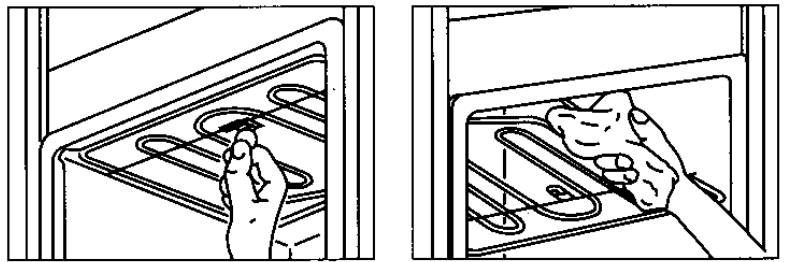

*Changing the Oven Light Bulb**

- Step 1: Remove cover (A) by unscrewing in an anti-clockwise direction.
- Step 2: Replace bulb (15 W ES)
- Step 3: Replace cover (A) by screwing in a clockwise direction.

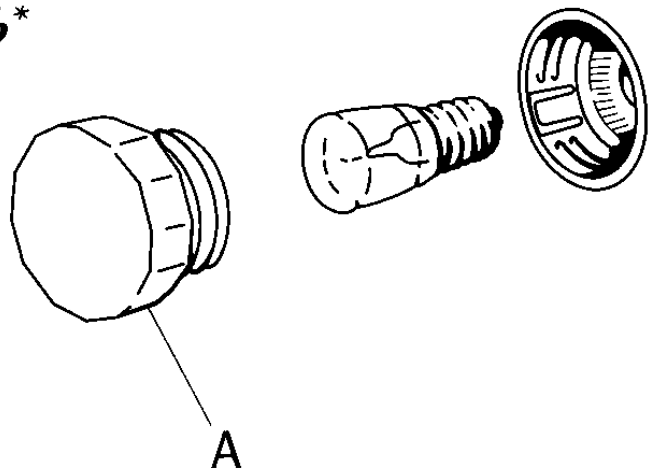

*Light bulbs are not covered by warranty.

Cleaning the Oven Glass

You now have easy access to the interior of the oven. To clean the door glass, use a coin or large screwdriver to loosen the screws. Wipe both sides of the inner, middle and outer glass.

Wipe sealing gasket.

Don't forget to replace the rubber sealing gasket around the centre glass layer before replacing the glass. Ensure the narrow air gap lies between the inner and centre glass layers and the wider gap lies between the centre and outside glass layers.

Tighten each screw gradually, one then the other until firm. Do not overtighten.

SCALA OVEN TO6A, TO31A, TO32A & TO33A

Appliance Warranty Details

In addition to all statutory rights which you, the Consumer, have under all the relevant laws in respect of this appliance, during the first 5 years ownership as the original purchaser of the Kleenmaid Scala oven, we guarantee that any fault caused by faulty material or workmanship becoming apparent, will be rectified free of charge for parts or labour, provided that all service is performed during normal work hours by Kleenmaid or their designated Agent. Where the appliance is installed outside the normal servicing areas as above, the Purchaser must pay the cost of transporting the appliance to and from the Agent or the Agent's travelling cost to and from the Purchaser's home.

*Warranty does not cover replacement light globes.

Please complete your warranty card and post it to us.

To assist you when calling our Customer Service number to arrange a service call, please complete the following and have these details ready when you call.

Model No.* _____

Retailer (Where appliance purchased) _____

Date of purchase ___/___/___

Date of installation ___/___/___

Should you require service, please call our Customer Service Dept/Office on 1-800-072-144 (freecall).

** The oven Model No. is shown on the inside lower section of the large oven door.*

Acknowledgment

With thanks to the Kleenmaid Demonstrators who provided the recipes included in this booklet.

Appliance Warranty Details

In addition to all statutory rights which you, the Consumer, have under all the relevant laws in respect of this appliance, during the first 3 years ownership as the original purchaser of the Kleenmaid Scala oven, we guarantee that any fault caused by faulty material or workmanship becoming apparent, will be rectified free of charge for parts or labour, provided that all service is performed during normal work hours by Kleenmaid or their designated Agent. Where the appliance is installed outside the normal servicing areas as above, the Purchaser must pay the cost of transporting the appliance to and from the Agent or the Agent's travelling cost to and from the Purchaser's home.

*Warranty does not cover replacement light globes.

Please complete your warranty card and post it to us.

To assist you when calling our Customer Service number to arrange a service call, please complete the following and have these details ready when you call.

Model No.* _____

Retailer (Where appliance purchased) _____

Date of purchase ___/___/___

Date of installation ___/___/___

Should you require service, please call our Customer Service Dept/Office on 1-800-072-144 (freecall).

** The oven Model No. is shown on the inside lower section of the large oven door.*

Acknowledgment

With thanks to the Kleenmaid Demonstrators who provided the recipes included in this booklet.